



INSTRUCTIONS FOR
PROFESSIONAL COIL SPRING COMPRESSOR SET
2500KG
 MODEL NO: **RE229.V3**

Thank you for purchasing a Sealey product. Manufactured to a high standard, this product will, if used according to these instructions, and properly maintained, give you years of trouble free performance.

IMPORTANT: PLEASE READ THESE INSTRUCTIONS CAREFULLY. NOTE THE SAFE OPERATIONAL REQUIREMENTS, WARNINGS & CAUTIONS. USE THE PRODUCT CORRECTLY AND WITH CARE FOR THE PURPOSE FOR WHICH IT IS INTENDED. FAILURE TO DO SO MAY CAUSE DAMAGE AND/OR PERSONAL INJURY AND WILL INVALIDATE THE WARRANTY. KEEP THESE INSTRUCTIONS SAFE FOR FUTURE USE.



Refer to
 Instruction
 Manual



Wear eye
 Protection

1. SAFETY

- ▲ **DANGER!** Stop compressing the spring before the coil windings touch, fig.2.A. Exercise particular caution when using an air impact wrench.
- **WARNING!** Ensure Health & Safety, local authority, and general workshop practice regulations are adhered to when using this equipment.
- **WARNING!** Wear approved safety eye protection (standard spectacles are not adequate).
- **WARNING!** Do not compress the spring to an extent where the jaws touch, fig.2.B.
- ✗ **DO NOT** operate spring compressor if parts are damaged or missing as this may cause failure and/or personal injury.
- ✗ **DO NOT** force the spring compressor to achieve a task it was not designed to perform.
- ✗ **DO NOT** allow untrained persons to use the spring compressor.
- ✓ Familiarise yourself with the applications, limitations and potential hazards of the spring compressor.
- ✓ Maintain the spring compressor in good condition. Replace or repair damaged parts. Use genuine parts only. Unauthorised parts may be dangerous and will invalidate the warranty.
- ✓ Keep the work area clean, uncluttered and ensure there is adequate lighting.
- ✓ Keep hands and body clear of the spring when operating the spring compressor.
- ✓ Maintain correct balance and footing. Ensure the floor is not slippery and wear non-slip shoes.
- ✓ Remove ill fitting clothes. Remove ties, watches, rings, other loose jewellery. Contain and/or tie back long hair.
- ✓ Wear appropriate protective clothing.
- ✓ When not in use, clean and store the spring compressor in a safe, dry, childproof location.

2. INTRODUCTION

Suitable for MacPherson strut coil springs. Features a yoke extension bracket that also allows use on conical springs. Supplied with three pairs of different sized interchangeable yokes, for a wide range of vehicle applications and plastic yoke protectors that protect the spring coating from damage which can invalidate the vehicle manufacturer's warranty. Safety yokes carefully shaped to stop the spring bowing while under compression.

3. SPECIFICATION

Model No:.....**RE229.V3**
 Capacity:..... 1000kg
 Yoke Specification (Size/Suitability):
 Gold Yokes:..... Ø80-105mm
 Black Yokes:..... 105-140mm
 Silver Yokes:..... Ø145-190mm
 Maximum jaw opening:..... 265mm
 Drive: 21mm hex

4. DESCRIPTION

Refer to fig.1

4.1 The compressor consists of a solid steel body mounted with two forged jaw interlocks, one on the body and the other on a centrally mounted spindle.

- | | |
|-------------------|----------------|
| 1 Retaining bolts | 5 Spring |
| 2 Yoke | 6 Safety clips |
| 3 Compressor body | 7 Outer rib |
| 4 Hex nut | |

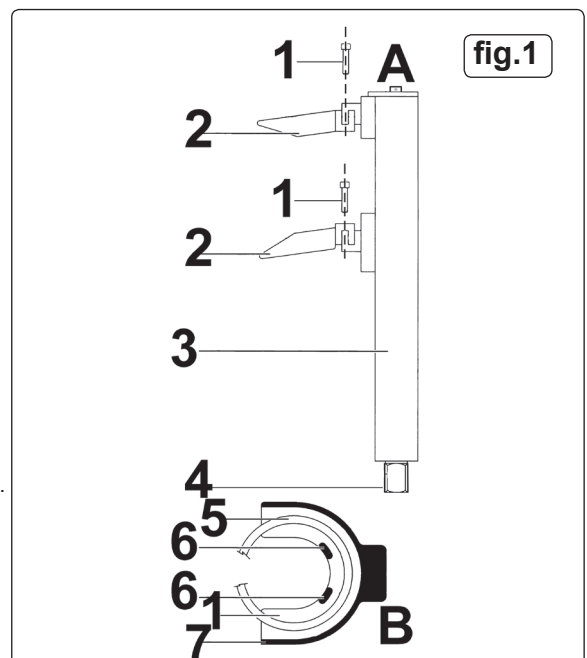

5. INSTRUCTIONS

- ❑ **WARNING!** Do not compress the spring to an extent where the coil windings or jaws touch, (Fig.2.A, Fig.2.B).
- ✓ Ensure the jaws and the body of the compressor are correctly aligned and well spaced at all times during spring compression (Fig.3.A). For conical springs, the centre line of the spring should remain parallel to the compressor body, (Fig.3.B).
- ✓ If necessary use the extension block as in Fig.4 to keep the spring and compressor body parallel.
- ✓ Secure the strut with a clamp, vice or other adequate holding device.

5.1. To Compress a Strut Removed From a Vehicle.

- 5.1.1. Mount the selected jaws on the compressor body, fit the retaining bolts and tighten securely.
- 5.1.2. Rotate the hexagonal nut, using air or hand tools to drive the jaws apart to the length of the spring and to allow compression of as many windings as possible.
- 5.1.3. Place the spring strut compressor onto the spring, ensuring the spring seats correctly (Fig.1.B) between the safety lips (Fig.1.6) and the outer rib (Fig.1.7) and cannot slide out during compression.
- 5.1.4. Ensure the jaws and body are correctly aligned, (Figs.3 / 4).
- 5.1.5. Rotate the hexagonal nut, using air or hand tools and compress the spring until the upper support bearing is free and the spring will rotate.

5.2. To Decompress a Strut Removed From a Vehicle.

- 5.2.1. To decompress the spring, reverse the compress procedure.

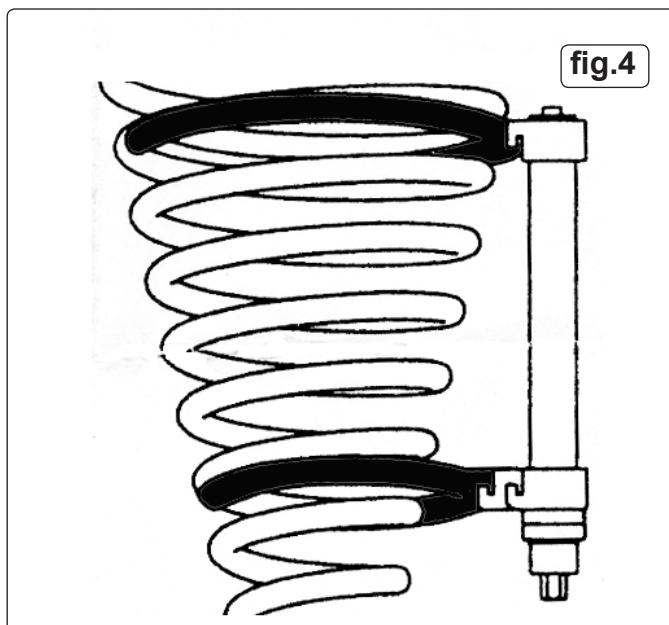
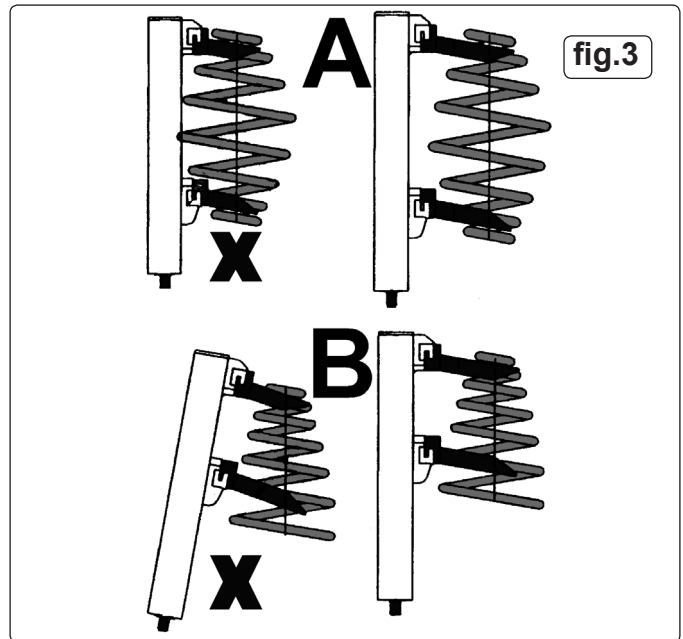
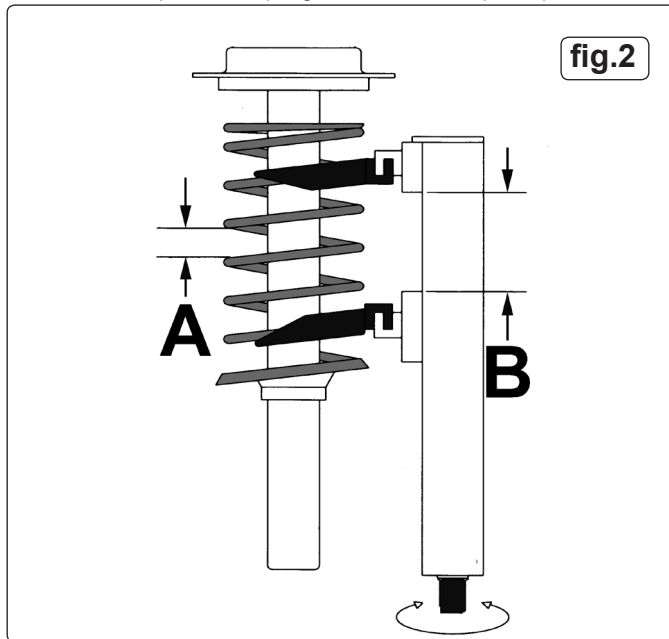

6. MAINTENANCE

- 6.1. Before each use check the compressor to ensure it is not damaged or worn.
- 6.2. If suspect, do not use the unit, but contact your local Sealey Dealer who will be able to advise you regarding repair kits and spare parts.
- 6.3. Grease the compressor spindle as necessary, at least every six months.
- 6.4. Keep the compressor clean, and when not in use, store in a safe, dry, childproof location.



Environmental Protection

Recycle unwanted materials instead of disposing of them as waste. All tools, accessories and packaging should be sorted, taken to a recycling centre and disposed of in a manner which is compatible with the environment. When the product becomes completely unserviceable and requires disposal, drain off any fluids (if applicable) into approved containers and dispose of the product and the fluids according to local regulations.

Parts support is available for this product. To obtain a parts listing and/or diagram, please log on to www.sealey.co.uk, email sales@sealey.co.uk or telephone 01284 757500.

NOTE: It is our policy to continually improve products and as such we reserve the right to alter data, specifications and component parts without prior notice.

IMPORTANT: No liability is accepted for incorrect use of this product.

WARRANTY: Guarantee is 12 months from purchase date, proof of which will be required for any claim.



Sole UK Distributor, Sealey Group.
Kempton Way, Suffolk Business Park,
Bury St. Edmunds, Suffolk.
IP32 7AR



01284 757500



01284 703534



www.sealey.co.uk



sales@sealey.co.uk