

Thank you for purchasing a Sealey product. Manufactured to a high standard this product will, if used according to these instructions and properly maintained, give you years of trouble free performance.



IMPORTANT: BEFORE USING THIS PRODUCT, PLEASE READ THE INSTRUCTIONS CAREFULLY. MAKE CAREFUL NOTE OF SAFETY INSTRUCTIONS, WARNINGS AND CAUTIONS. THIS PRODUCT SHOULD ONLY BE USED FOR ITS INTENDED PURPOSE. FAILURE TO DO SO MAY CAUSE DAMAGE AND/OR PERSONAL INJURY AND WILL INVALIDATE THE WARRANTY. RETAIN THESE INSTRUCTIONS FOR FUTURE USE.

1. SAFETY INSTRUCTIONS

1.1 GENERAL SAFETY

- ✓ Only use the sprayer for its intended purpose.
- ✓ Familiarise yourself with the applications, limitations, and potential hazards of this product.
- ✓ Use original Sealey spare parts only. Unauthorised parts may be dangerous and will invalidate the warranty.
- ✓ Ensure containers cannot easily be knocked over during filling.
- ✓ Always ensure good contact on the 12V battery.
- ✓ Mark fluid containers with hazard labels to show their contents.
- ✓ Keep any fluid containers in a well ventilated, lockable store, preferably outside the working area.
- ✓ Keep children and unauthorised persons away from the working area, especially when the sprayer is in operation.
- ✓ Keep the work area childproof by using padlocks and master switches.
- ✓ Maintain the sprayer in top condition. Keep it clean for best and safest performance.
- ✓ Follow the same precautions when transferring fluid from the sprayer back into other containers.
- ✓ Ensure the sprayer is securely fixed to the ATV.
- ✓ Always inspect and prepare the sprayer before use according to the directions provided in this manual.
- ✓ Keep the sprayer turned off. Do not turn on power to the sprayer until ready to spray in order to avoid unintentional spray release.
- X Never spray when wind speed exceeds 4mph in order to minimize spray drift.
- X **DO NOT** over apply pesticide. Apply at a rate recommended by agents manufacturer. Excess pesticide can be dangerous to humans, damage desirable plants, and contaminate soil and water sources.
- X Never point the spray gun at people or animals.
- X **DO NOT** eat, drink, rub your eyes, or touch any part of your bare skin while handling agents and spraying.
- X **DO NOT** spray near open flames or sources of heat.
- ✓ Always clean up spills immediately per instructions on the agents label.
- ✓ Turn off vehicle and set brake or block wheels, turn off power to sprayer, and relieve system pressure before leaving sprayer unattended.
- X **DO NOT** use an open flame or smoke anywhere near the sprayer or around stored fluid.
- X **DO NOT** spray fluid into dedicated workshop oil spray equipment.
- X **DO NOT** use any electrical equipment on or near the vehicle while fluid spraying is in progress. This includes the use of inspection lights, mobile phones or pagers.
- X **DO NOT** use the sprayer if the pump is damaged in any way.
- X **DO NOT** use whilst under the influence of drugs, alcohol or other intoxicating medication, or if you are fatigued.

1.2 ELECTRICAL CONNECTION SAFETY

- ✓ If the battery terminals are corroded or dirty, clean them before using the tester.
- ✓ Disconnect the power after every use to avoid accidental starting.
- X **DO NOT** disassemble the remote switch for any reason. The tester must only be checked by qualified service personnel.

- **WARNING!** To prevent the risk of sparking, short circuit and possible explosion **DO NOT** drop metal tools in the battery area, or allow them to touch the battery terminals.
- X **DO NOT** cross-connect remote switch clamps. Ensure positive (RED) clamp is to positive terminal and negative (BLACK) clamp is to negative terminal.

1.3 CHEMICAL SAFETY

- 1.3.1 First and foremost ensure you read the safety data sheet of the substance you are going to spray.
- 1.3.2 The sprayer is intended for use in spraying agricultural pesticides and other non-flammable liquids.
- 1.3.3 Spraying pesticides - Pesticides are hazardous agents that must be handled with caution as directed throughout this manual and on the pesticide label. The sprayer is intended for use in spraying pesticides in liquid form only. The sprayer is NOT intended for use in spraying pesticides in dry or in aerosol form, or for use with fumigants. Sprayers SS60 and SS98 come equipped with a spot spray gun and a tank-mounted broadcast spraying system. Use the spot spray gun if you desire to apply pesticide only on selected plants. Use the broadcast spraying system if you wish to spray large ground areas.
- 1.3.4 Spraying Other Liquids - In addition to spraying pesticides, this sprayer may be used to spray other non-flammable liquids. Example uses include: watering plants/trees or spraying water for dust control, applying ice control agents, applying water-based, non-flammable sealant or stain to outdoor wood surfaces.
- 1.3.5 However, WE RECOMMEND THAT THE SPRAYER NOT BE USED FOR OTHER PURPOSES ONCE IT HAS ALREADY BEEN USED FOR SPRAYING PESTICIDES. Any agents will leave some residual in the tank liner or sprayer components, even after the sprayer has been properly cleaned. These residual agents can have unexpected effects on future uses. For example, spraying water or other liquids that are contaminated with residual pesticide may result in unforeseen hazards to plant or animal life.

2. INTRODUCTION

ATV spot/broadcast sprayers supplied with tie-down straps to attach to most all terrain vehicles. Powered by 12V battery or connected via 12V supply on ATV. Quiet running diaphragm pump is pressure activated producing a smooth flow from the tank. Supplied with trigger operated lance providing controlled application and broadcast lance for hands-free operation. Features remote operated on/off switch and battery clips. Tank is manufactured using chemical resistant material and is fitted with tank drainage spout for draining unwanted contents. Tank also features extra-thick walls and is UV-stabilized to prevent fading. Suitable for use with a variety of different agents including weed killer, de-icer and for spraying fertilizer.

3. SPECIFICATION

Model No.	SS60	SS98
Tank Capacity	60ltr	98ltr
Maximum Flow Rate	8.3ltr/m	8.3ltr/m
Maximum Pressure	70psi	70psi
Maximum Spray Reach	4.3m	4.3m
Hose Length	4.5m	4.5m
Dimensions (W x D x H)	864 x 368 x 419mm	864 x 368 x 622mm
Weight	8.4kg	9.9kg

4. CONTENTS

4.1 Main Contents

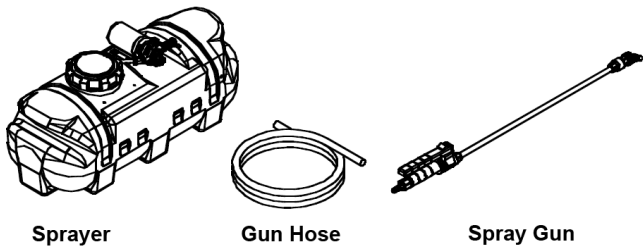

4.2 Accessories and Fixings

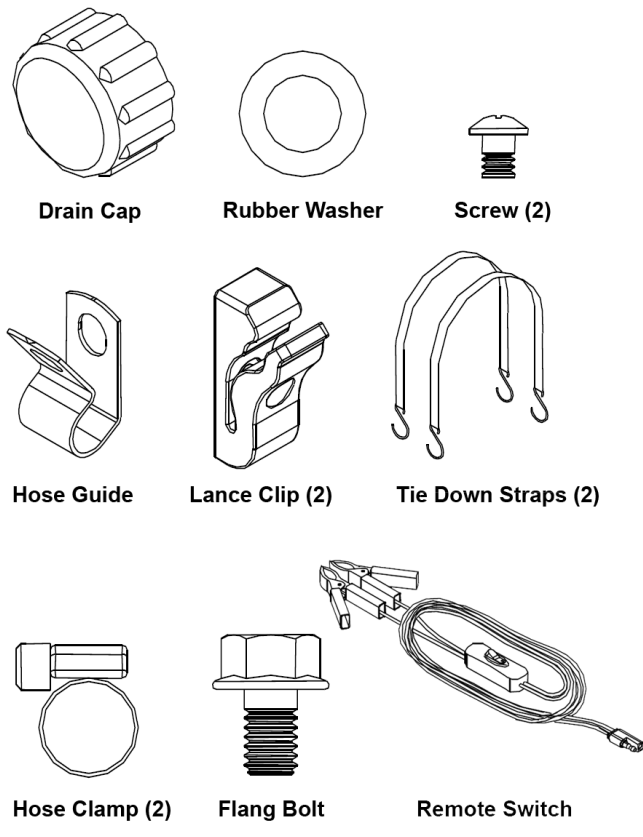

4.3 Broadcast Lance and Fixings

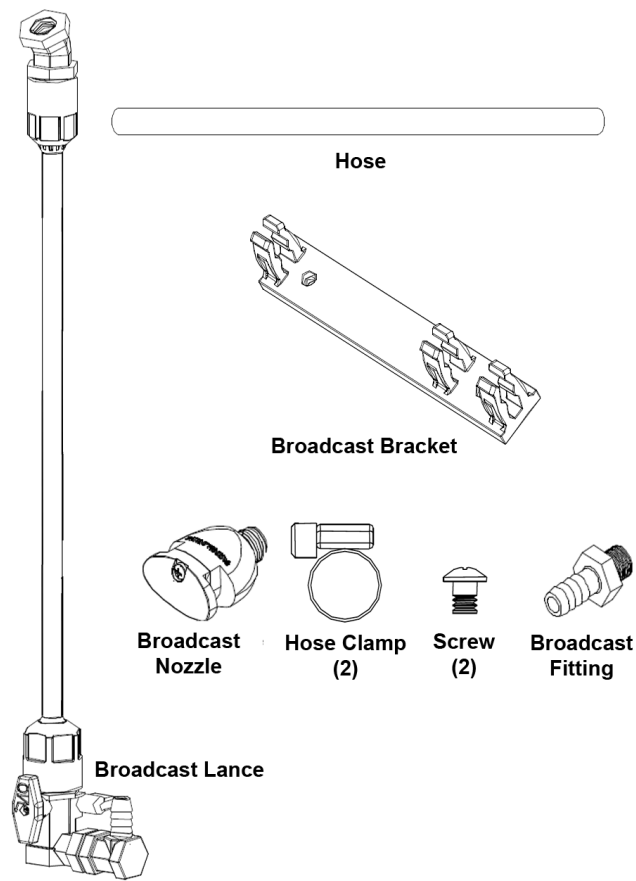

5. ASSEMBLY

- 5.1 Fasten the two lance clips to the sprayer tank with the two screws supplied. See fig.1.
- 5.2 Press the rubber washer onto the drain pipe, screw on the drain cap. See fig.1.

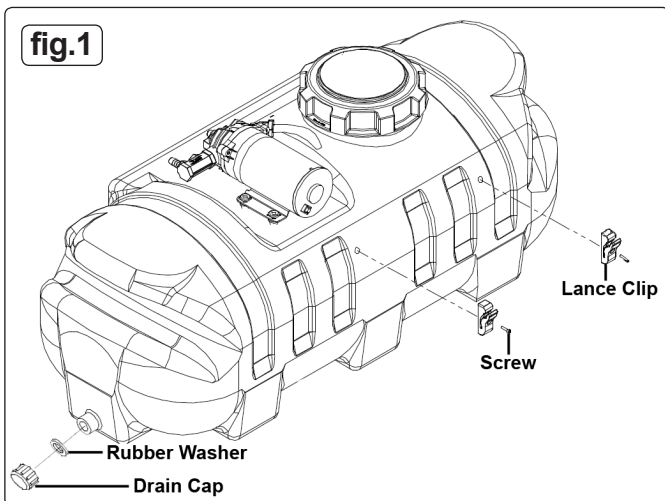

5.3 Attach Spot Spray Gun Hose to Pump (see fig.2)

- 5.3.1 Slide the hose clamp over the hose.
- 5.3.2 Push the hose onto the pump.
- 5.3.3 Slide the hose clamp over the pump connector and tighten.

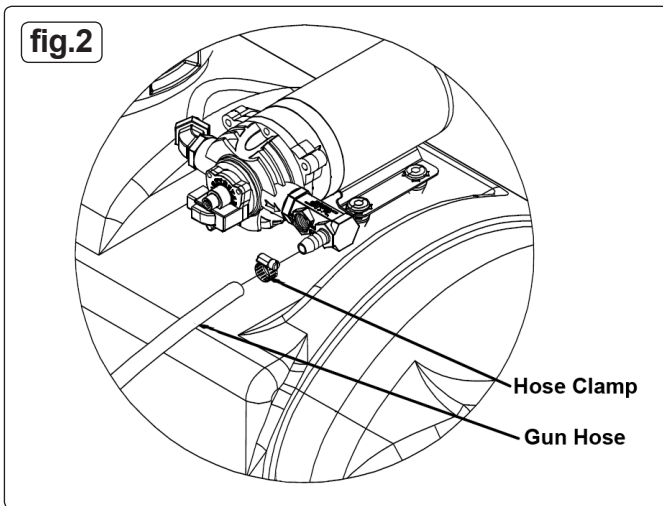

5.4 Attach Hose Guide to Tank (see fig.3)

- 5.4.1 Thread the hose through the hose guide.
- 5.4.2 Attach the guide to the side of the tank using the flange bolt.

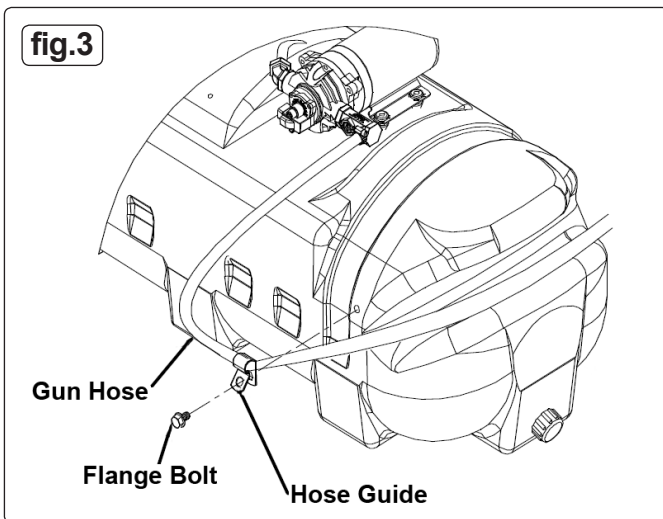

5.5 Attach Hose to Spot Spray Gun (see fig.4)

- 5.5.1 Slide the hose clamp over the hose.
- 5.5.2 Push the hose onto the hose barb on the spray gun.
- 5.5.3 Slide the hose clamp around the hose barb and tighten.

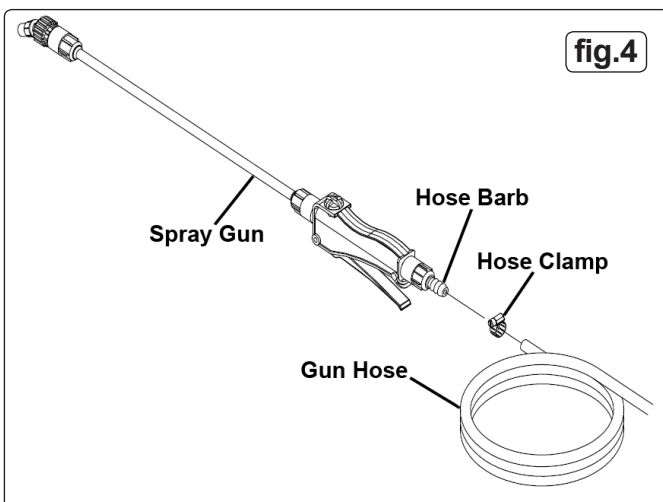

5.6 Attach Broadcast bracket to Tank (see fig.5)

- 5.6.1 Ensure the bracket is fixed with the two clips at the end facing the pump.

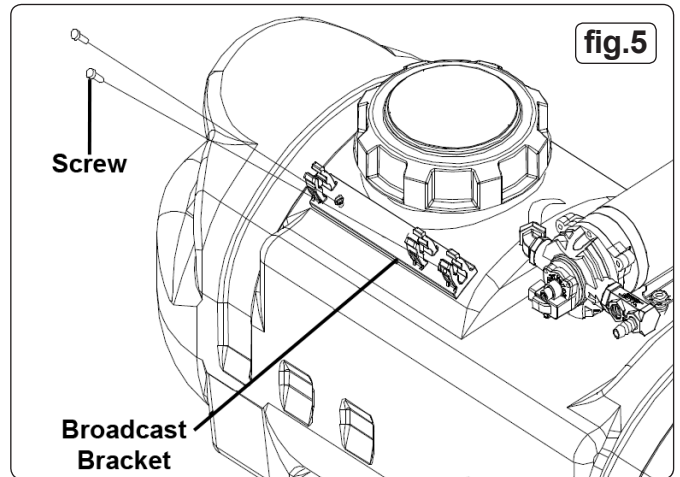

5.7 Assemble Broadcast Kit. (see fig.6)

- 5.7.1 Insert the broadcast lance into the bracket, note the orientation in fig.6.
- 5.7.2 Screw on the hose connector to the pump, tighten by hand then using a spanner turn once more.
- 5.7.3 Slide two hose clamps over the hose.
- 5.7.4 Push the hose onto the hose barb on the broadcast lance and onto the connector on the pump.
- 5.7.5 Slide the hose clamp around the hose barbs and tighten.

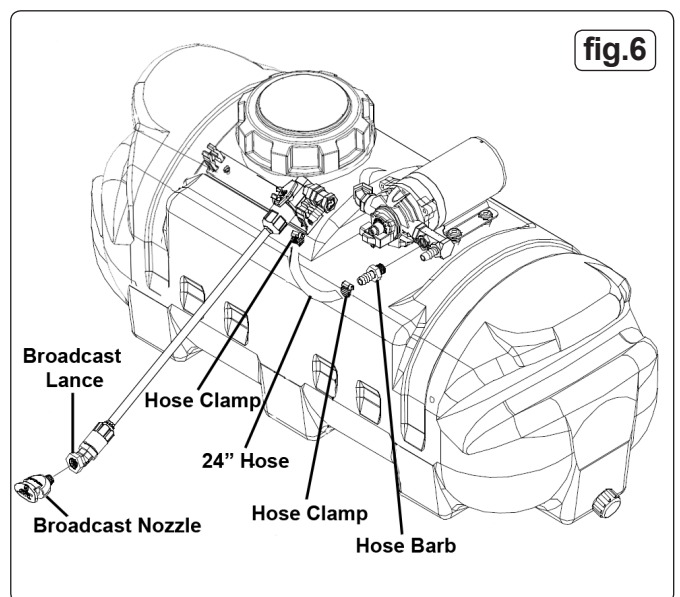

5.8 Attach the sprayer to the vehicle (see fig.7)

- 5.8.1 Use the hooked straps supplied to secure each end to an ATV rack (not supplied)

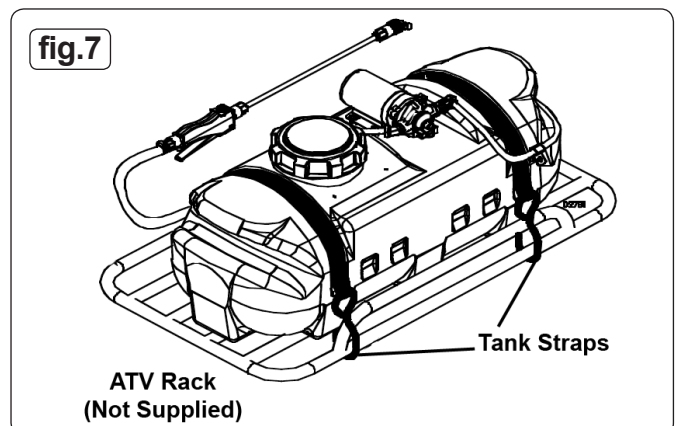

5.9 Connect the Remote Switch to Battery

- 5.9.1 Disconnect the vehicle's earth cable from the negative battery terminal.
- 5.9.2 Connect the red positive clamp to the positive (+) terminal on the battery.
- 5.9.3 Connect the black negative clamp to the negative (-) terminal on the battery.
- 5.9.4 Reconnect the vehicle earth cable.

5.10 Connect the remote switch the pump

- 5.10.1 Ensure the remote switch is in the OFF position (O).
- 5.10.2 Connect the remote switch to the power cable leading from the rear of the pump.

NOTE: The power cables will only connect one way.

5.11 Testing

- 5.11.1 Check that the gun clip screws are tight, hose clamps are secure, and tank straps are properly fastened.
- 5.11.2 While it is unlikely that factory-assembled components become loose, they should also be checked to make sure they are tight.
- 5.11.3 Fill the tank with water test the system for leaks with water.
- 5.11.4 Connect the remote switch to the pump power cord and turn the remote switch ON. The pump is an "on demand" pump. When turned on, the pump will prime itself, then turn off. When the gun trigger is squeezed, the pump will automatically start.
- 5.11.5 Operate the spray gun by squeezing the gun trigger.
- 5.11.6 Check for leaks throughout the system. If a leak is detected, fix the leak and re-test the system with water until no leaks are detected.

6. PREPARATION

6.1 Preparation

- 6.1.1 Ensure the sprayer is securely attached to the vehicle.
- 6.1.2 Ensure the sprayer has been thoroughly flushed and drained of all residual agents from prior uses.
- 6.1.3 Clean the suction strainer of any agents residue. It is important to clean the suction strainer before each use to ensure it is not clogged and to prevent residual agents from contaminating sprayer contents.

6.2 Environment Considerations

- 6.2.1 The sprayer should not be used when wind is in excess of 4mph.
- 6.2.2 Consideration should be given to members of the public and/or colleagues when spraying, ensure the area to be sprayed is well ventilated and cordoned off.

6.3 Filling the sprayer

- 6.3.1 Choose a safe pesticide mixing and loading area. Choose an outdoor, well-ventilated area away from unprotected people, animals, food, and other items that might become contaminated.
- 6.3.2 Wear personal protective equipment.
- 6.3.3 Turn off power to the sprayer before filling. The vehicle should also be off, with wheels chocked to prevent unintended movement.
- 6.3.4 Remove the fill cap located on top of the sprayer. (fig.8).

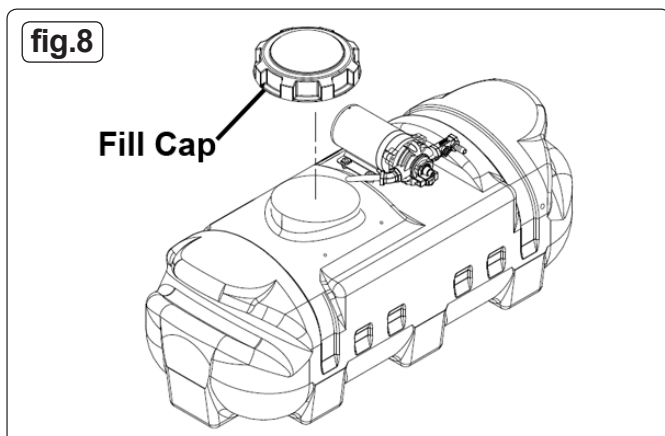

- 6.3.5 Before filling ensure drain cap is securely tightened.
- 6.3.6 Mix agents as instructed on that particular product. Do not mix more than needed, to reduce wastage and the need to store excess agents mix.
- 6.3.7 Pour agent through the filler cap. When done replace filler cap and tighten.

7. USE - SPOT SPRAYER

7.1 Personal Protective Equipment

- 7.1.1 Ensure personal protective equipment is used. i.e gloves, goggles, coverall and breathing mask.

7.2 Broadcast Lance Valve

- 7.2.1 Turn the broadcast lance to the OFF position (fig.9).

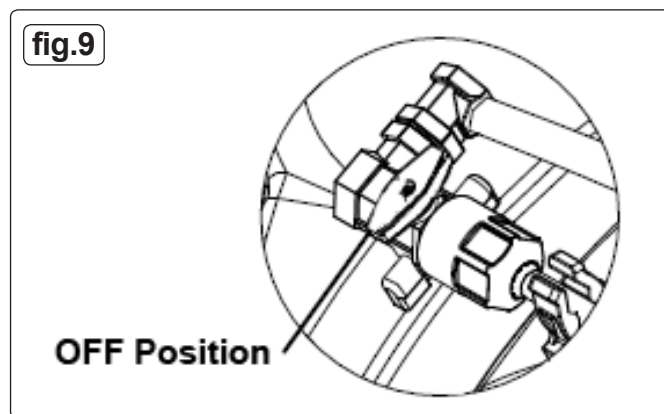

7.3 Turn On Power

- 7.3.1 Turn the remote switch to the ON (I) position.

7.4 Use Spot Spray Gun

- 7.4.1 To spray squeeze the gun trigger.
- 7.4.2 Twist the spray nozzle to change from a straight stream to a cone spray pattern. Check with the type of agent which is best to use.

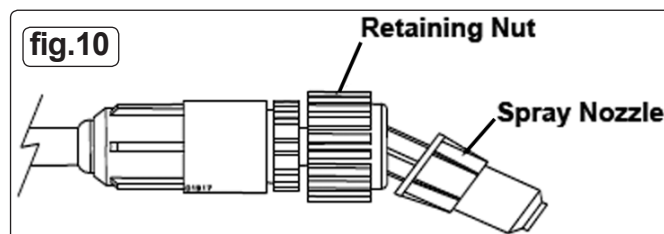

8. USE - BROADCAST SPRAYER

8.1 Broadcast Lance

- 8.1.1 Move the broadcast lance into the broadcast position (fig.11).
- 8.1.2 Ensure the broadcast lance valve is in the OFF position (fig.11).

Stored Position

fig.11

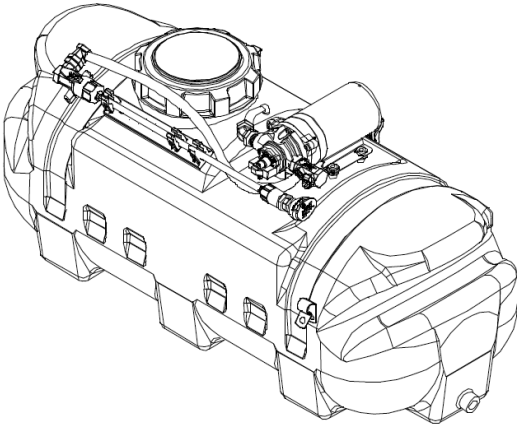

Broadcast Position

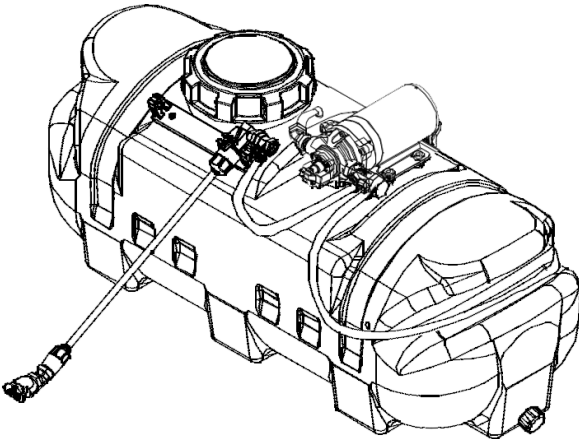

OFF Position

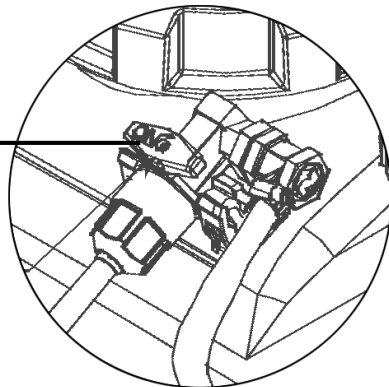

8.2 Broadcast Nozzle

- 8.2.1 If needed, rotate the broadcast nozzle so that the spray pattern is pointed down and evenly distributed. (fig.12)
- 8.2.2 Ensure gloves are worn when adjusting the lance and nozzle, as dripping may occur.

fig.12

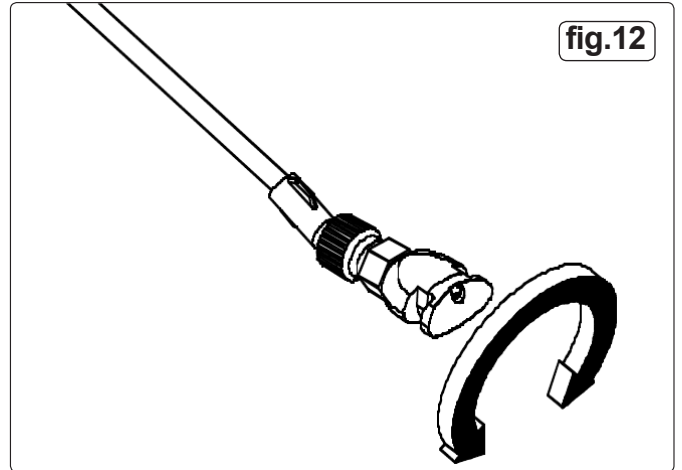

8.3 Start Spraying

- 8.3.1 Turn the remote switch to ON (I).
- 8.3.2 Turn the broadcast lance valve on (fig.13).

fig.13

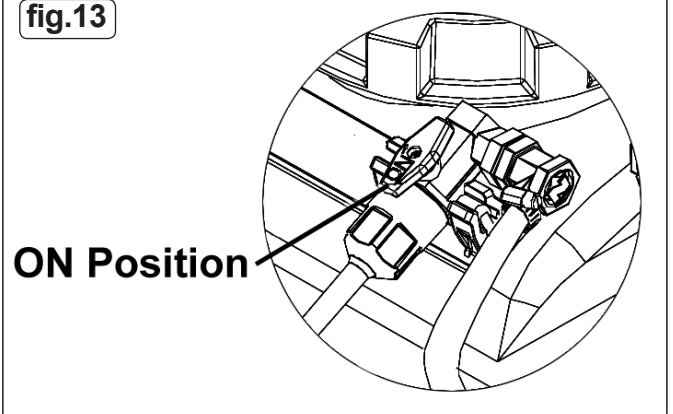

- 8.3.3 To ensure a uniform spray pattern, overlap each spray 300mm (fig.14).
- 8.3.4 See the speed/application tables to determine the speed for the ATV.

fig.14

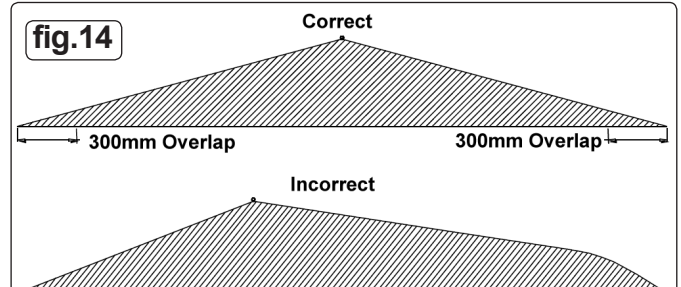

NOTE! It is possible to use the broadcast lance and spot spray gun simultaneously.

8.4 Leaving Unattended

- 8.4.1 If the sprayer must be left unattended; A) disconnect the power. B) relieve the system pressure by pressing the gun trigger. C) turn off the vehicle and chock the wheels.

8.5 Sprayer Becomes Inoperable

- 8.5.1 If the sprayer becomes clogged or stops working do not attempt to repair whilst agents are still in the sprayer tank.
- 8.5.2 Review the troubleshooting table to proceed.

9. AFTER USE

9.1 Drain Tank

- 9.1.1 Disconnect the power supply and relieve the system pressure by squeezing the spray gun trigger.
- 9.1.2 Use a suitable container to drain excess agent into, place it beneath the drain hole.
- 9.1.3 Remove the drain cap to drain into container. Ensure all personal protective equipment is used.
- 9.1.4 When the tank is fully drained, replace drain cap and tighten.

9.2 Unused Chemicals

- 9.2.1 If unused agents are to be kept for future use store in the original container or a similarly suitable one. Also ensure such container is suitably labelled.
- 9.2.2 When remaining agents need to be disposed of, refer to the manufactures label and local authority guidelines.

9.3 Flush Sprayer

- 9.3.1 Refer to agents manufacturer for flushing procedure and recommendation on a cleaning solution.

9.4 Decontaminate

- 9.4.1 After handling chemicals and other agents, remove all clothing and wash separate to other clothing.
- 9.4.2 Wash all exposed skin thoroughly with soap and water.

10. STORAGE

10.1 Preparing for Storage

- 10.1.1 Add an antifreeze (not automotive) into the tank.
- 10.1.2 Turn on the pump and squeeze the gun trigger until the antifreeze sprays briefly. Store the gun in the lance clips and disconnect the power.

10.2 Removing form Storage

- 10.2.1 Drain the antifreeze into a suitable container.
- 10.2.2 Fill the sprayer tank with fresh clean water, connect the power, use the spray gun and flush the system. Be sure to have a container to collect the flushed antifreeze.
- 10.2.3 Dispose of antifreeze along with local authority guidelines.

11. TROUBLESHOOTING

SYMPTOMS	REASON	REMEDY
Pump will not start.	1. Poor electrical connection. 2. Short in wires 3. Low voltage.	1. Ensure good connections. 2. Check conditions of wires. 3. Check the battery voltage.
Low pressure.	1. Worn spray gun nozzle. 2. Worn boom nozzle.	1. Replace spray gun nozzle. 2. Replace boom nozzle.
Low flow.	1. Clogged intake tube. 2. Clogged suction strainer. 3. Low voltage.	1. Remove obstruction to intake tube. 2. Clean suction strainer. 3. Check the battery voltage.
Poor spray distribution.	1. Clogged intake tube. 2. Clogged suction strainer. 3. Worn spray gun nozzle	1. Remove obstruction to intake tube. 2. Clean suction strainer. 3. Replace spray gun nozzle.
Pump operates while not spraying.	1. Leak in the system	1. Find leak and tighten hose clamps or fittings. Replace spray gun.

12. SPRAY CALIBRATION

Follow the below tables to determine the correct speed that the ATV should travel.

12.1 Table 1

- 12.1.1 Use the table that corresponds with the agents manufacturer's suggested application rate (litres per hectare, litres per 100 sq.m or litres per 10 sq.m).
- 12.1.2 Find the application rate that is closest to the agents manufacturer's recommendations.

Litres per Hectare							
Application Rate	800	400	267	200	160	133	144
Speed (km/h)	1	2	3	4	5	6	7
Litres per 100Sq.m.							
Application Rate	8.0	4.0	2.6	2.0	1.6	1.3	1.1
Speed (km/h)	1	2	3	4	5	6	7
Litres per 10Sq.m.							
Application Rate	0.80	0.40	0.26	0.20	0.16	0.13	0.11
Speed (km/h)	1	2	3	4	5	6	7

12.2 Table 2

- 12.2.1 Use this table to set the speed of the ATV.

Speed (km/h)	Time Required in Seconds to Travel a Distance of:		
	10m	50m	100m
1	36	180	360
2	18	90	180
3	12	60	120
4	9	45	90
5	7	35	70
6	6	30	60
7	5	25	50

NOTE: It is our policy to continually improve products and as such we reserve the right to alter data, specifications and component parts without prior notice.

IMPORTANT: No liability is accepted for incorrect use of this product.

WARRANTY: Guarantee is 12 months from purchase date, proof of which will be required for any claim.

INFORMATION: For a copy of our latest catalogue and promotions call us on 01284 757525 and leave your full name and address, including postcode.



Sole UK Distributor, Sealey Group,
Kempson Way, Suffolk Business Park,
Bury St. Edmunds, Suffolk,
IP32 7AR



01284 757500



www.sealey.co.uk



01284 703534



sales@sealey.co.uk