



INSTRUCTIONS FOR

AC/DC CLAMP METER & MULTIMETER

MODEL NO: TA305

Thank you for purchasing a Sealey product. Manufactured to a high standard, this product will, if used according to these instructions, and properly maintained, give you years of trouble free performance.

IMPORTANT: PLEASE READ THESE INSTRUCTIONS CAREFULLY. NOTE THE SAFE OPERATIONAL REQUIREMENTS, WARNINGS & CAUTIONS. USE THE PRODUCT CORRECTLY AND WITH CARE FOR THE PURPOSE FOR WHICH IT IS INTENDED. FAILURE TO DO SO MAY CAUSE DAMAGE AND/OR PERSONAL INJURY AND WILL INVALIDATE THE WARRANTY. KEEP THESE INSTRUCTIONS SAFE FOR FUTURE USE.



Refer to
instruction
manual

1. SAFETY

- WARNING!** To avoid possible electric shock or personal injury, follow these guidelines:
 - DO NOT** use the meter if it is damaged. Before you use the meter, inspect the case. Pay particular attention to the insulation surrounding the connectors.
 - ✓ Inspect the test leads for damaged insulation or exposed metal. Check the test leads for continuity. Replace damaged test leads before using the meter.
 - ✗ **DO NOT** use the meter if it operates abnormally. Protection may be impaired. When in doubt, have the meter serviced.
 - ✗ **DO NOT** operate the meter around explosive gas, vapour, or dust. Don't use it under wet conditions.
 - ✗ **DO NOT** apply more than the rated voltage, marked on the meter, between terminals or between any terminal and earth ground.
 - ✓ Before use, verify the meter's operation by measuring a known voltage.
 - ✓ Use caution when working with voltage above 30V ac rms, 42V peak, or 60V dc. Such voltages pose a shock hazard.
 - ✓ When using the probes, keep your fingers behind the finger guards on the probes.
 - ✓ Connect the common test lead before you connect the live test lead. When you disconnect test leads, disconnect the live test lead first.
 - ✓ Remove the test leads from the meter and remove the clamp jaws from the conductor under test before opening the case or the battery cover.
 - ✗ **DO NOT** operate with the battery cover or portions of the case removed or loosened.
 - ✓ To avoid false readings, which could lead to possible, electric shock or personal injury, replace the batteries as soon as the low battery indicator () appears.
 - ✓ To avoid electric shock, do not touch any naked conductor with hand or skin.
 - ✗ **DO NOT** hold the meter anywhere beyond the finger guard.
 - ✓ Adhere to local and national safety codes. Individual protective equipment must be used to prevent shock and arc blast injury where hazardous live conductors are exposed.
 - ✗ **DO NOT** use the test leads with other equipment.
 - ✗ When an input terminal is connected to dangerous live potential, this potential can occur at all other terminals!
- CAT III - Measurement** (Category III is for measurements performed in building installation.)
Examples are measurements on distribution boards, circuit breakers, wiring, including cables, bus-bars, junction boxes, switches, socket-outlets in the fixed installation, and equipment for industrial use and some other equipment, for example, stationary motors with permanent connection to fixed installation.
DO NOT use the meter for measurements within Measurement Categories IV.
- WARNING!** To avoid possible damage to the meter or to the equipment under test, follow these guidelines:
 - ✓ Disconnect circuit power and discharge all capacitors before testing resistance, diode and continuity.
 - ✓ Use the proper function and range for your measurements.
 - ✓ Before rotating the function switch to change functions, remove test leads from the circuit under test and remove the jaws from the clamped conductor.

2. INTRODUCTION

Designed for the automotive electrician and conforms to **EN61010 CAT III 600V**. Ideal for measuring current draw from vehicle components in situ. Features 12mm clamp. Supplied in pouch.

Measures:

- AC and DC voltage
- AC and DC current
- Resistance
- Audible continuity
- Diode test

3. SPECIFICATION

Model no:**TA305**

Display:3 3/4-digit LCD, with a max. reading of 3999

Negative Polarity Indication:

..... negative sign “ - ” shown on the display automatically

Overrange Indication: OL shown on the display

Jaw Opening Capability: 12mm

Max.Measurable Conductor: 12mm

Battery: 1.5V battery, AAA or equivalent x2

Low Battery Indication: shown on the display



Operation Environment: 0°C to 40°C, < 75%RH

Storage Environment: -10°C- 50°C, < 85%RH

Size:226 x 71 x 38mm

Weight: about 185g (including batteries)

AC voltage

| Range | Resolution | Accuracy | Overload Protection |
|---------|------------|---------------|---------------------|
| 400.0mV | 0.1mV | not specified | 600V rms |
| 4.000V | 1mV | ± (1.2% + 5) | |
| 40.00V | 10mV | ± (1.5% + 5) | |
| 400.0V | 100mV | | |
| 600V | 1V | | |

Input impedance:..... 10MΩ

Frequency range:.....40Hz

Max. allowable input voltage:.....600V rms

Response:..... Average, calibrated in rms of sine wave

Note: The 400.0mV range is available only in manual range mode.

DC voltage

| Range | Resolution | Accuracy | Overload Protection |
|---------|------------|--------------|---------------------|
| 400.0mV | 0.1mV | ± (0.8% + 5) | 600V rms |
| 4.000V | 1mV | ± (1.0% + 5) | |
| 40.00V | 10mV | | |
| 400.0V | 100mV | | |
| 600V | 1V | | |

Input impedance:..... range 400.0mV:> 100MΩ
for the other ranges: 10MΩ

Max. allowable input voltage: 600V dc

AC current

| Range | Resolution | Accuracy | Overload protection |
|--------|------------|--------------|---------------------|
| 40.00A | 0.01A | ± (2.5% + 5) | 200A rms |
| 100.0A | 0.1A | ± (2.5% + 5) | |

Display:sine wave rms, average response

Frequency range:50 ~ 60Hz

Max. allowable input current: AC100A

Response:..... Average, calibrated in rms of sine wave

Temperature coefficient: ±0.3% of reading/°C

DC current

| Range | Resolution | Accuracy | Overload protection |
|--------|------------|--------------|---------------------|
| 40.00A | 0.01A | ± (2.5% + 5) | 200A rms |
| 100.0A | 0.1A | ± (2.5% + 5) | |

Max. allowable input current:DC100A

Temperature coefficient: ±0.3% of reading/°C

Resistance

| Range | Resolution | Accuracy | Overload Protection |
|---------|------------|--------------|---------------------|
| 400.0Ω | 100mΩ | ± (1.2% + 7) | 600Vrms |
| 4.000kΩ | 1Ω | ± (1.0% + 5) | |
| 40.00kΩ | 10Ω | | |
| 400.0kΩ | 100Ω | | |
| 4.000MΩ | 1kΩ | ± (1.2% + 5) | |
| 40.00MΩ | 10kΩ | ± (1.5% + 7) | |

Continuity

| Range | Resolution | Description | Overload Protection |
|-------|------------|--|---------------------|
| •)) | 100mΩ | If the resistance is less than 50Ω, the buzzer will sound. | 600V rms |

Note: When the resistance is between 50Ω and 150Ω, the buzzer may or may not sound. When the resistance is more than 150Ω, the buzzer will not sound.

Diode

| Range | Resolution | Description | Overload Protection |
|-------|------------|---|---------------------|
| ➔ | 1mV | The approx. forward voltage drop of the diode will be displayed. Open Circuit Voltage: about 1.5V Test Current: about 0 - 0.6mA | 600V rms |

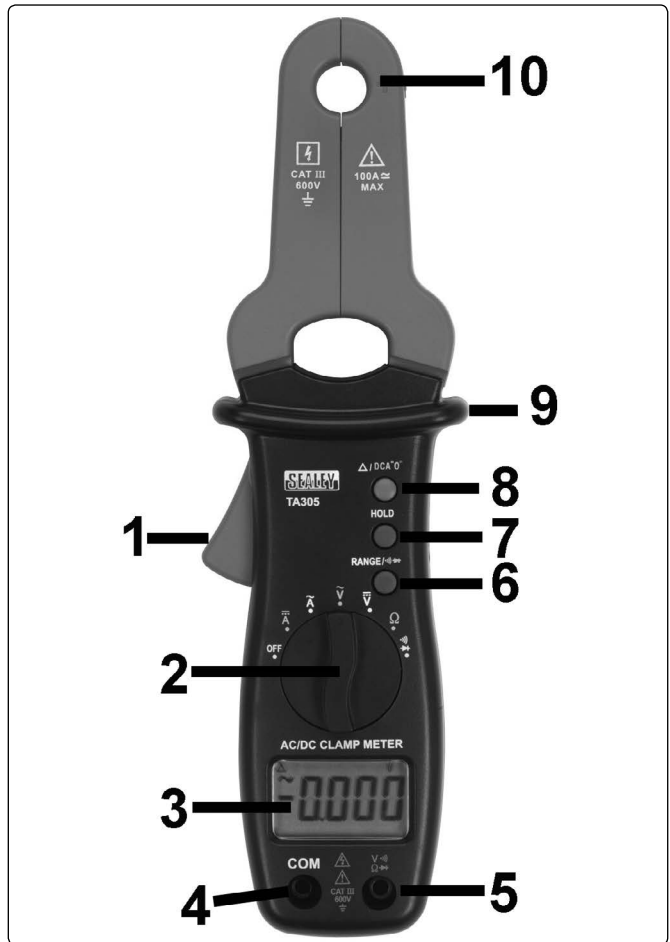

4. CONTROLS

1. **Trigger**
Used to open and close jaws.
 2. **Function switch**
Select desired function as well as to turn meter on and off.
 3. **Display**
3¾ - digit LCD, with max. reading of 3999 and unit indication.
 4. **COM terminal**
Plug in terminal for black test lead.
 5. **V-Ω-⊕ terminal**
Plug in terminal for the red test lead.
 6. **RANGE/⊕-⊕ Button**
(i) In voltage, current or resistance measurement function this button is used to switch between autorange mode and manual range mode as well as to select desired manual range.
(ii) In continuity or diode test function, this RANGE/⊕-⊕ button is used to switch between continuity and diode test functions.
 7. **HOLD Button**
Used to enter/exit Data Hold mode.
 8. **Δ/DCA'0**

In dc current measurements this button is used for zeroing before measurement.
In other measurements, this button can be used to enter/exit Relative mode.
 9. **Finger guard**
 10. **Jaws**
Used to clamp conductor for current measurements.
- Buzzer**
Buzzer sounds if a button is pressed.

Before the meter turns off automatically, the meter will emit 5 short beeps, 1 minute later it will emit a long beep then turn off automatically.

5. OPERATION

5.1. Data Hold Mode

- 5.1.1. Press the "HOLD" button to hold the present reading on the display, **H** will appear on the display as an indicator.
- 5.1.2. To exit the Data Hold mode, just press this button again, **H** disappears.

5.2. Relative Mode

- 5.2.1. Selecting relative mode makes the meter store the present reading as a reference for subsequent measurements and zero the display.
- 5.2.2. Press the $\Delta/DCA"0"$ button. The meter enters relative mode and stores the present reading for subsequent measurements.
- 5.2.3. The triangle symbol Δ appears on the display as an indicator. The display reads zero.
- 5.2.4. When a new measurement is taken, the display shows the difference between the reference and the new measurement.
- 5.2.5. To exit Relative mode, press the $\Delta/DCA"0"$ button again and the Δ disappears.

Note:

- (i) For measurement functions which have both autorange mode and manual range mode, the meter changes to manual range mode automatically when you select Relative mode. Select the desired manual range before you select Relative mode.
- (ii) When you use Relative mode, the actual value of the object under test must not exceed the full-range reading of the selected range. Use a higher range if necessary.

5.3. Manual Ranging and Autoranging

- 5.3.1. The meter defaults to autorange mode in measurement functions which have both autorange mode and manual range mode. When the meter is in autorange mode, "Auto" is displayed.
- 5.3.2. Press the **RANGE** button to enter the manual range mode. The symbol "Auto" disappears.
- 5.3.3. Each press of the **RANGE** button increases the range. When the highest range is reached, the meter scrolls to the lowest range.
- 5.3.4. To exit the manual range mode, press and hold down the **RANGE/** button for about 2 seconds. The meter returns to the autorange mode, and "Auto" appears.

Note: Only voltage, current and resistance measurement functions have autorange mode and manual range mode.

5.4. Measuring AC Voltage

- 5.4.1. Connect black test lead to the **COM** terminal and the red test lead to the **V Ω** terminal.
- 5.4.2. Set the function switch to the **V \sim** position.
- 5.4.3. Connect the test leads across the source or circuit to be tested.
- 5.4.4. Read the reading on the display. The polarity of the red test lead connection will be indicated as well.

Note: To avoid electric shock or damage to the meter, do not apply a voltage higher than 600V between terminals.

5.5. Measuring DC Current

- 5.5.1. Set the function switch to the **A $\overline{\sim}$** position.
- 5.5.2. If the display does not read zero, press the $\Delta/DCA"0"$ button for zeroing.
- 5.5.3. Press the trigger and clamp the jaws around the conductor to be tested. Make sure that the jaws are perfectly closed.

Note:

- a. Only one conductor should be clamped.
- b. The conductor should be in the centre of the jaws to get an accurate reading.
- c. **DO NOT** touch any conductor with any part of the body.

- 5.5.4. Read the reading on the display.

Note:

- (i) Remove all the test leads from the meter before using the meter for current measurements.
- (ii) After you set the function switch to the **A $\overline{\sim}$** position, wait 5 to 10 minutes before proceeding. This is necessary for accurate measurements.
- (iii) The meter's measuring capacity is 100A. Measuring a current higher than 100A will cause a larger measurement error.
- (iv) The reading on the display also indicates the current's direction:
A positive reading (negative sign "-" does not appear) indicates that the current direction is from the meter's front to its back. (Note: Current direction is the opposite of electron flow direction).

- 5.5.5. **DO NOT** use the meter to measure a circuit's current if the circuit's voltage exceeds 600V.

5.6. Measuring AC Current

- 5.6.1. Set the function switch to the **A \sim** position.
- 5.6.2. Press the trigger and clamp the jaws around the conductor to be tested. Make sure the jaws are perfectly closed.

Note:

- (i) Only one conductor should be clamped.
- (ii) The conductor should be in the centre of the stand to get an accurate reading.
- (iii) **DO NOT** touch any conductor with any part of the body.

- 5.6.3. Read the reading on the display.

Note:

- (i) Remove all test leads from the meter before using the meter for current measurements.
- (ii) After the function switch is set to the **A \sim** position, wait 5 to 10 minutes before proceeding. This is necessary to obtain accurate measurements.
- (iii) The meter's measuring capacity is 100A. Measuring a current higher than 100A will cause a larger measurement error.
- (iv) **DO NOT** use the meter to measure a circuit's current if the voltage exceeds 600V.

5.7. Measuring resistance

- 5.7.1. Connect the black test lead to the **COM** terminal and the red test lead to the **V-Ω-▶** terminal.
- 5.7.2. Set the function switch to the **Ω** position.
- 5.7.3. Connect the test leads across the object to be tested.
- 5.7.4. Read the reading on the display.

Note:

- (i) If the resistance is more than 1MΩ it may take several seconds for the reading to stabilise. This is normal for high resistance measurements.
- (ii) If the input terminals are in an open circuit state, the over range indicator "OL" will be shown on the display.
- (iii) Before measurement, disconnect all power to the circuit to be tested and discharge all capacitors thoroughly.

5.8. Diode test

- 5.8.1. Connect the black test lead to the **V-Ω-▶** terminal. (The red test lead is positive "+".)
- 5.8.2. Set the function range switch to the **▶** position. Then press the **RANGE-▶** button until the **▶** symbol appears on the display.
- 5.8.3. Connect the red test lead to the anode of the diode to be tested and the black test lead to the cathode of the diode.
- 5.8.4. Read the approximate forward voltage drop of the diode on the display.

5.9. Continuity test

- 5.9.1. Connect the black test lead to the **COM** terminal and the red test lead to the **V-Ω-▶** terminal.
- 5.9.2. Set the range function switch to the **)))** position. Then press the **RANGE-)))▶** until the **)))** symbol appears on the display.
- 5.9.3. Connect the test leads across the circuit to be tested.
- 5.9.4. If the resistance is less than about 50Ω, the built-in buzzer will sound.

Note:

Before test, disconnect all power to the circuit to be tested and discharge all capacitors thoroughly.

5.10. Automatic Power Off

- 5.10.1. If the meter has not been used, or the function switch rotated for about 15 minutes, the meter will turn off automatically and go into Sleep mode.
- 5.10.2. To 'wake' the meter from Sleep mode, rotate the function switch or press a button.
- 5.10.3. If the **RANGE-)))▶** button is pressed to 'wake' the meter from Sleep mode, when the function switch is in the **▶** or **)))** position, the automatic power-off feature will be disabled.

6. MAINTENANCE

- 6.1. Periodically wipe the case with a damp cloth and mild detergent. **DO NOT** use abrasives or solvents.
- 6.2. **Cleaning terminals**
 - 6.2.1. Dirt or moisture in the terminals can affect readings. Clean the terminals as follows.
 - 6.2.2. Turn off the meter and remove test leads.
 - 6.2.3. Shake out any dirt that may be in the terminals.
 - 6.2.4. Soak a new swab with alcohol.
 - 6.2.5. Work the swab around in each terminal.
- 6.3. **Replace battery**
 - WARNING!** Remove the test leads from the meter and remove the jaws from the conductor under test before opening the case or the battery cover.
 - 6.3.1. When the low battery indicator () appears on the display the batteries should be replaced immediately.
 - 6.3.2. Remove the screw on the battery cover, replace the batteries with new batteries of the same type. Refit the battery cover and screw.

Environmental Protection



Recycle unwanted materials instead of disposing of them as waste. All tools, accessories and packaging should be sorted, taken to a recycling centre and disposed of in a manner which is compatible with the environment. When the product becomes completely unserviceable and requires disposal, drain off any fluids (if applicable) into approved containers and dispose of the product and the fluids according to local regulations.



WEEE Regulations

Dispose of this product at the end of its working life in compliance with the EU Directive on Waste Electrical and Electronic Equipment (WEEE). When the product is no longer required, it must be disposed of in an environmentally protective way. Contact your local solid waste authority for recycling information.

Battery Removal



See section 6.3 above.

Under the Waste Batteries and Accumulators Regulations 2009, Jack Sealey Ltd are required to inform potential purchasers of products containing batteries (as defined within these regulations), that they are registered with Valpak's registered compliance scheme. Jack Sealey Ltd's Batteries Producer Registration Number (BPRN) is BPRN00705.

NOTE: It is our policy to continually improve products and as such we reserve the right to alter data, specifications and component parts without prior notice.

IMPORTANT: No liability is accepted for incorrect use of this product.

WARRANTY: Guarantee is 12 months from purchase date, proof of which will be required for any claim.



Sole UK Distributor, Sealey Group.
Kempson Way, Suffolk Business Park,
Bury St. Edmunds, Suffolk.
IP32 7AR



01284 757500



01284 703534



www.sealey.co.uk



sales@sealey.co.uk