

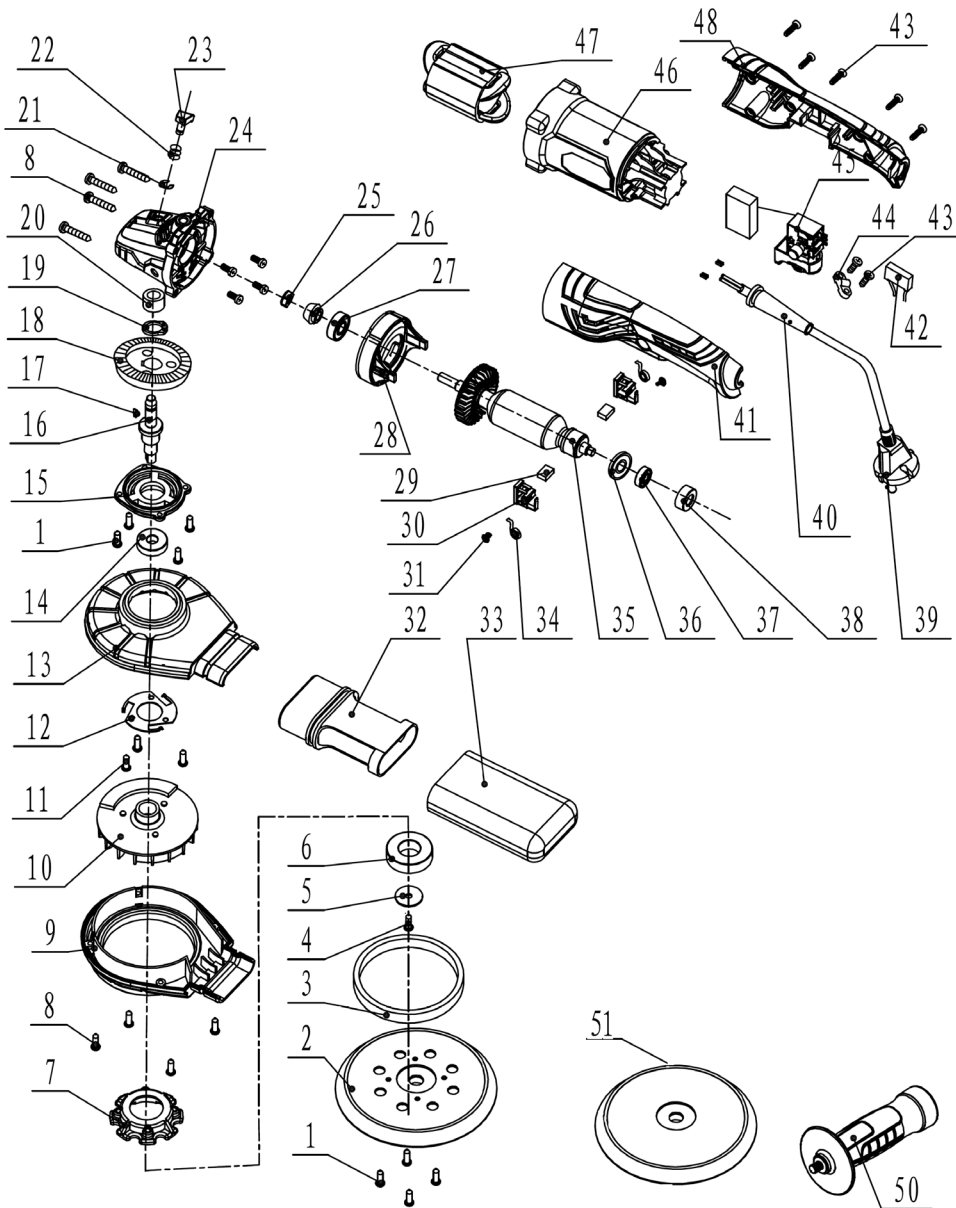

Parts Information:
Random Orb Sander Variable Speed Dust-Free Ø150mm 750W/230V
Model No: DAS151.V2



NOTE: It is our policy to continually improve products and as such we reserve the right to alter data, specifications and component parts without prior notice.

IMPORTANT: No liability is accepted for incorrect use of product.

WARRANTY: Guarantee is 12 months from purchase date, proof of which will be required for any claim.

Sealey Group, Kempson Way, Suffolk Business Park, Bury St Edmunds, Suffolk. IP32 7AR



01284 757500



01284 703534



sales@sealey.co.uk



www.sealey.co.uk



Parts Information:
Random Orb Sander Variable Speed Dust-Free Ø150mm 750W/230V
Model No: DAS151.V2

Item	Part No.	Description
1	MSP46.SB	Machine screw pan head phillips m4x6mm black
2	DAS151.V2-02	Ø150mm hook-and-loop backing pad
3	DAS151.V2-03	Felt Ring
4	MSP516.S	Machine screw pan head phillips m5x16mm (single)
5	RWB620.S	Repair washer m6x20 (single) 'black'
6	B/6003-2RS	Bearing 6003-2rs
7	DAS151.V2-07	Bearing Support
8	MSP422.SB	Pan head machine screw black m4x22
9	DAS151.V2-09	Lower Cover
10	DAS151.V2-10	Eccentric Fan
11	DAS151.V2-11	Stud
12	DAS151.V2-12	Fan Clamp
13	DAS151.V2-13	Upper Cover
14	B/6000-2RS	Bearing 6000-2rs
15	DAS151.V2-15	Gearcase Cover
16	DAS151.V2-16	Output Shaft
17	DAS151.V2-17	Output Shaft Key (3x3.5x10)
18	DAS151.V2-18	Gear
19	DAS151.V2-19	Circlip 10
20	B/HK0810	Needle bearing hk0810
21	DAS151.V2-21	C-Clip
22	DAS151.V2-22	Self-Lock Button Spring
23	DAS151.V2-23	Self-Lock Cap & Pin Set
24	DAS151.V2-24	Gearcase

Item	Part No.	Description
25	DAS151.V2-25	Locknut
26	DAS151.V2-26	Pinion
27	B/629-2RS	Bearing 629-2rs
28	DAS151.V2-28	Fan Baffle
29	DAS151.V2-29	Carbon Brush (pair)
30	DAS151.V2-30	Carbon Brush Holder (pair)
31	ER1700PD.55	Rd head s/t screw m3x8 black
32	DAS151.V2-32	Dust Collection Support
33	DAS151.V2-33	Dust Collection Bag
34	DAS151.V2-34	Carbon Brush Holder Spring
35	DAS151.V2-35	Rotor
36	DAS151.V2-36	Dust Ring
37	B/607ZZ	Bearing 607zz
38	DAS151.V2-38	Bearing Bush
39	DAS151.V2-39	Cable & Plug
40	DAS151.V2-40	Cord Sleeve
41	DAS151.V2-41	Left Side Handle
42	DAS151.V2-42	Capacitor
43	ER1700PD.12	Rd head s/t screw m4x16 black
44	DAS151.V2-44	Cord Clamp
45	DAS151.V2-45	Switch Assmbly
46	DAS151.V2-46	Stator Housing
47	DAS151.V2-47	Stator
48	DAS151.V2-48	Right Side Handle
50	DAS151.V2-50	Side Handle
51	DAS151.V2-51	Foam Pad Ø150mm

NOTE: It is our policy to continually improve products and as such we reserve the right to alter data, specifications and component parts without prior notice.

IMPORTANT: No liability is accepted for incorrect use of product.

WARRANTY: Guarantee is 12 months from purchase date, proof of which will be required for any claim.

Sealey Group, Kempson Way, Suffolk Business Park, Bury St Edmunds, Suffolk. IP32 7AR



01284 757500



01284 703534



sales@sealey.co.uk



www.sealey.co.uk