



MOTORCYCLE STEERING BEARING PRESS

MODEL NO: **SMC3**

Thank you for purchasing a Sealey product. Manufactured to a high standard, this product will, if used according to these instructions, and properly maintained, give you years of trouble free performance.

IMPORTANT: PLEASE READ THESE INSTRUCTIONS CAREFULLY. NOTE THE SAFE OPERATIONAL REQUIREMENTS, WARNINGS & CAUTIONS. USE THE PRODUCT CORRECTLY AND WITH CARE FOR THE PURPOSE FOR WHICH IT IS INTENDED. FAILURE TO DO SO MAY CAUSE DAMAGE AND/OR PERSONAL INJURY AND WILL INVALIDATE THE WARRANTY. KEEP THESE INSTRUCTIONS SAFE FOR FUTURE USE.



Refer to instructions



Wear eye protection



Wear protective gloves



Wear safety footwear



Wear protective clothing

1. SAFETY

- ❑ **WARNING!** Ensure Health & Safety, local authority, and general workshop practice regulations are adhered to when using this equipment.
- ❑ **WARNING!** Always wear approved eye protection when using the press. Failure to do so may result in serious injury. Normal spectacles are not adequate protection.
- ✓ Familiarise yourself with the specific applications and limitations of the press, as well as any potential hazards.
- ✓ If unsure of the applications or limitations of the press, contact your supplier.
- ✓ Ensure that the press is the correct tool for the task. **DO NOT** use the press for any purpose other than that for which it is designed.
- ✓ Replace or repair damaged parts. Use genuine parts only. Unauthorised parts may be dangerous and will invalidate the warranty.
- ✓ Ensure that the workpiece is stable and that there is adequate lighting.
- ✓ Maintain correct balance and footing. Ensure the floor is not slippery and wear non-slip shoes.
- ✓ Ensure that the front of the motorcycle frame is adequately supported when the front wheel and forks are removed.
- ✗ **DO NOT** use press if any parts are damaged or missing as this may cause failure and/or personal injury.
- ✗ **DO NOT** use the press when you are tired or under the influence of alcohol, drugs or intoxicating medication.
- ✓ Keep children and unauthorised persons away from the working area.
- ✓ When not in use, return parts to the case, and store in a safe, dry, childproof location.

2. INTRODUCTION

Aluminium kit suitable for straight installation of bearing race without damage to the bearings or headstock. Includes seven dies for bearing sizes ranging from 32 to 46mm. Bearing setting bar features seven increments for a wide range of headstock sizes. Comfort grip T-handle rotates separately from the press plate for smooth bearing installation. Once the bearing has been set, use the bearing seating tool to finish installation.

3. SPECIFICATION

Model no. SMC3
 Die sizesØ32, Ø36, Ø38, Ø42 (x3), Ø46mm
 Setting bar length..... 420mm
 Setting bar increments 6 x 30mm, 1 x 42mm

4. OPERATION

4.1. TOP BEARING RACE INSERTION

- 4.1.1. Position top bearing race in headstock and select appropriate size die, one which is slightly smaller than the diameter of the bearing race.
- 4.1.2. Slide the pressure plate onto the bearing setting bar allowing it to click into one of its positions. Then push the assembly up through the headstock, bearing race and die. Wind the winding handle onto the bar and re-adjust the pressure plate to the correct setting (fig.3.2).
- 4.1.3. Wind the winding handle so that the bearing race is pushed into the headstock. When in place release the pressure plate (fig.3.3).

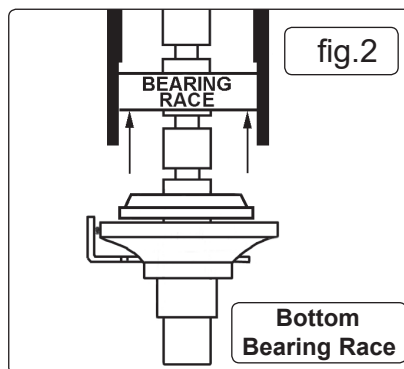
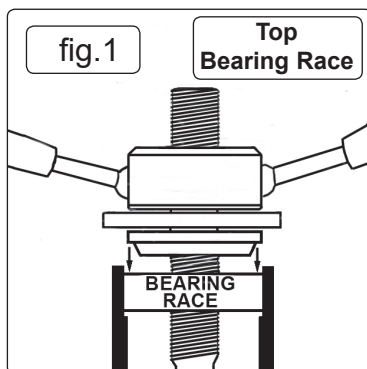

4.2. BOTTOM BEARING RACE INSERTION

- 4.2.1. Position bottom bearing race in headstock and select appropriate size die, one which is slightly smaller than the diameter of the bearing race.
- 4.2.2. Slide the pressure plate onto the bearing setting bar, allowing it to click into one of its positions (fig.3.4). Continue to wind the winding handle onto the bar so that the bearing race is pushed into the headstock (fig.3.5). When in place release the pressure plate and remove the assembly from the headstock.
- 4.2.3. To ensure that both bearing races are fully driven home, place the die onto the die handle, position it over the bearing race and using a soft faced hammer, drive the bearing race home. Return all parts to the case, and store in a safe, dry, childproof location.

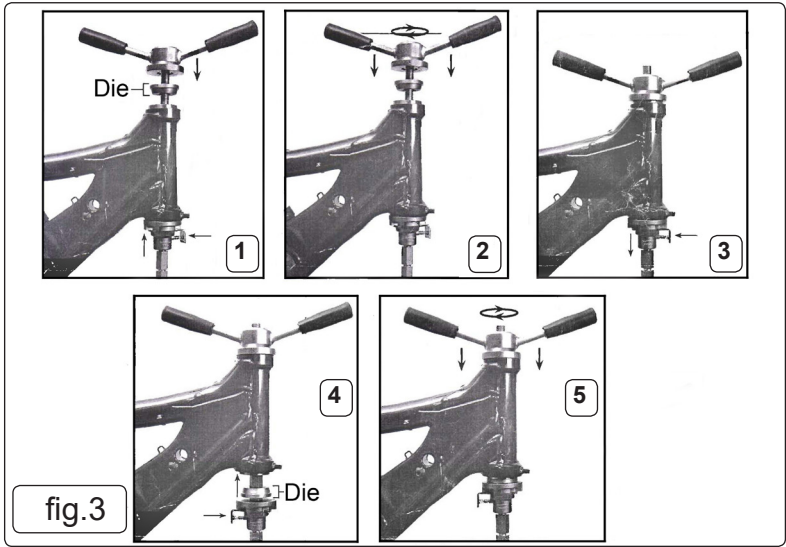

5. PARTS

SMC3.01	STEP DIE 32mm	SMC3.11	SLIDING LEVER
SMC3.02	STEP DIE 36mm	SMC3.12	HANDLE
SMC3.03	STEP DIE 38mm	SMC3.13	BLOW MOULD CASE
SMC3.04-6	STEP DIE 42mm		
SMC3.07	STEP DIE 46mm		
SMC.08	DRIVE HANDLE		
SMC.09	SLIDING PRESS PLATE		
SMC.10	HEX SHAFT		

Parts support is available for these products. Please email sales@sealey.co.uk or telephone 01284 757500

ENVIRONMENT PROTECTION
 Recycle unwanted materials instead of disposing of them as waste. All tools, accessories and packaging should be sorted, taken to a recycling centre and disposed of in a manner which is compatible with the environment. When the product becomes completely unserviceable and requires disposal, drain any fluids (if applicable) into approved containers and dispose of the product and fluids according to local regulations.

Note: It is our policy to continually improve products and as such we reserve the right to alter data, specifications and component parts without prior notice.
Important: No Liability is accepted for incorrect use of this product.
Warranty: Guarantee is 12 months from purchase date, proof of which is required for any claim.

Sealey Group, Kempson Way, Suffolk Business Park, Bury St Edmunds, Suffolk. IP32 7AR
 ☎ 01284 757500 📠 01284 703534 ✉ sales@sealey.co.uk 🌐 www.sealey.co.uk