



# HEAVY-DUTY MOTORCYCLE CHAIN SPLITTER & RIVETING TOOL SET

MODEL NO: **SMC4**

Thank you for purchasing a Sealey product. Manufactured to a high standard, this product will, if used according to these instructions, and properly maintained, give you years of trouble free performance.

**IMPORTANT:** PLEASE READ THESE INSTRUCTIONS CAREFULLY. NOTE THE SAFE OPERATIONAL REQUIREMENTS, WARNINGS & CAUTIONS. USE THE PRODUCT CORRECTLY AND WITH CARE FOR THE PURPOSE FOR WHICH IT IS INTENDED. FAILURE TO DO SO MAY CAUSE DAMAGE AND/OR PERSONAL INJURY AND WILL INVALIDATE THE WARRANTY. KEEP THESE INSTRUCTIONS SAFE FOR FUTURE USE.



Refer to instructions



Wear eye protection



Wear protective gloves



Wear safety footwear



Wear protective clothing

## 1. SAFETY

- ❑ **WARNING!** Ensure Health and Safety, local authority and general workshop practice regulations are adhered to when using tools.
- \* **DO NOT** use this tool if any parts are missing or damaged.
- \* **DO NOT** use this tool for any purpose other than that for which it is designed.
- ✓ Wear approved eye protection. A full range of personal safety equipment is available from your Sealey stockist.
- ✓ Wear suitable clothing to avoid snagging. **DO NOT** wear jewellery and tie back long hair.
- ✓ Maintain correct balance and footing, **DO NOT** over-reach. Ensure the floor is not slippery and wear non-slip shoes.
- ✓ Keep children and other unauthorised persons away from the working area.
- ✓ Keep yourself and tools away from hot engine parts.
- ✓ Maintain the tool components in a good and clean condition for best and safest performance.
- ✓ Replace or repair damaged parts. Use genuine parts only. Unauthorised parts may be dangerous and will invalidate the warranty.
- ✓ Ensure that the motorcycle is standing on a level surface and that it is adequately supported on its own centre stand, or by other means, before commencing any work.
- ✓ Ensure that the motorcycle's engine is turned off.
- \* **DO NOT** use this tool when you are tired or under the influence of alcohol, drugs or intoxicating medication.
- ✓ When work is completed, clean tools and replace in the carrying case and store in a safe, dry, childproof location.
- \* **DO NOT** use power tools or extensions with these tools. Hand tighten only.

## 2. INTRODUCTION

Comprehensive set designed to shorten and lengthen motorcycle chains by removing or replacing links. Set is also ideal for use on horticultural and agricultural machinery. Includes tools designed for riveting and plate holder for connecting links accurately.

## 3. CONTENTS

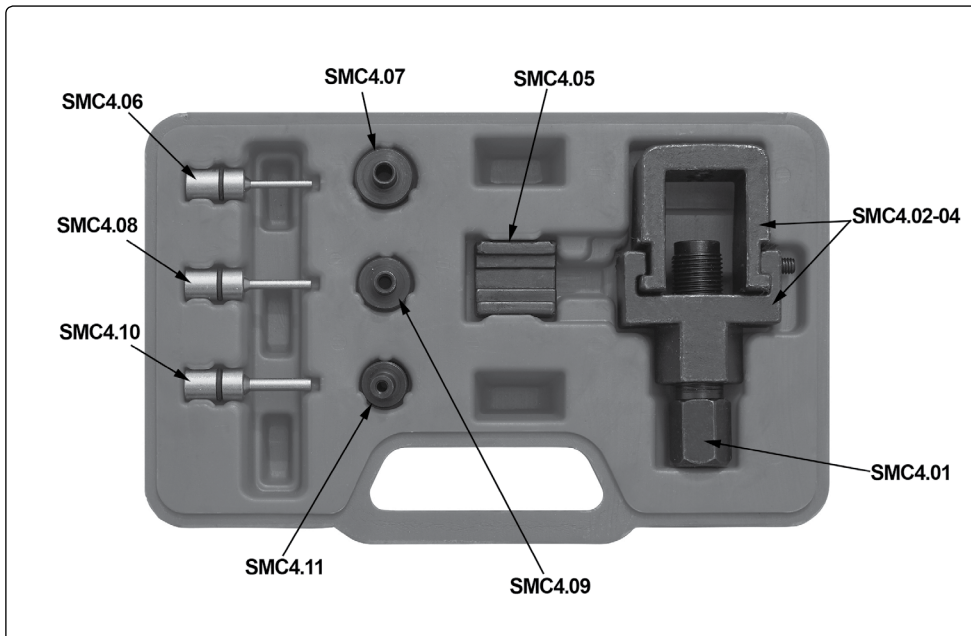

Item No.	Description
SMC4.01	Pin Holder
SMC4.02-04	Main Body
SMC4.05	Plate Holder
SMC4.06	Pin 3mm
SMC4.07	Anvil 3mm
SMC4.08	Pin 4mm
SMC4.09	Anvil 4mm
SMC4.10	Pin 5mm
SMC4.11	Anvil 5mm
SMC4.12	Blow Mould Case

## 4. OPERATION

**IMPORTANT:** These instructions are provided as a guide only. Always refer to the motorcycle manufacturer's service instructions, or a proprietary manual, to establish the current procedure and data, also any warnings or cautions particular to the motorcycle. Before commencing work, ensure that the tool is suitable for the selected chain size and connecting link. Ensure that the new connecting link is of the same size and type as the chain to be connected. The pins in this set are consumable parts and therefore not covered by the warranty. When selecting a pin, ensure that it is not too big for the chain pin, as it may jam in the chain, or too small, as it may break.

### 4.1. DISASSEMBLING A CHAIN

**NOTE:** Grind the rivet head on No. 520 and greater chains.

- 4.1.1. Fit a suitably sized pin for the size of chain, into the pin holder (fig.2.2). Ensure that it is pushed fully home. Ensure that the pin holder is wound back into the body to allow enough space for it to fit around the chain.
- 4.1.2. Position the matching sized anvil into the aperture in the U holder and place the U holder over the chain link to be removed (fig.2.1).
- 4.1.3. Slide the pin holder body onto the U holder and tighten the securing screw in position A (fig.2.3).
- 4.1.4. Ensure that the chain link is correctly positioned against the hole in the anvil at the rear of the U holder, and screw in the pin holder until the pin is touching the face of the chain link pin to be removed. Check that everything is lined up.
- 4.1.5. Use a 27mm spanner to hold the pin holder body and a 19mm spanner to turn the pin holder. Turn the pin holder clockwise and proceed to start pushing out the link pin from the chain. Re-check that all parts are lined up and that the pin is centred on the link pin. Continue to push out the link pin (fig.2.4).

**Note:** If excessive resistance is felt initially and there is difficulty in turning the pin holder, the pin may be too large for the link pin. Try one size smaller pin and anvil if possible.

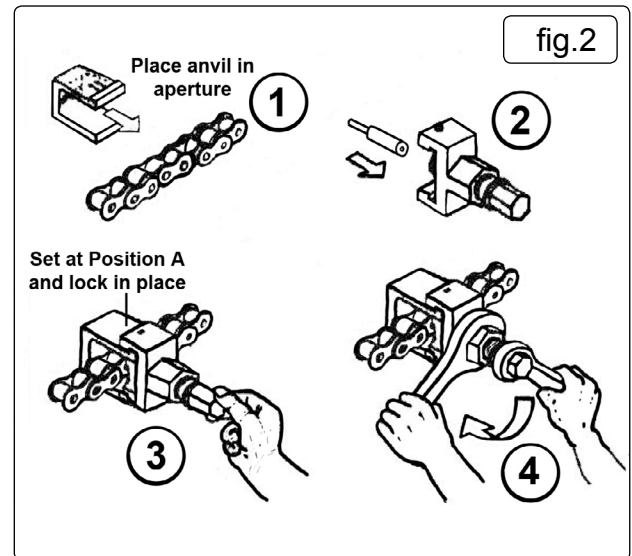
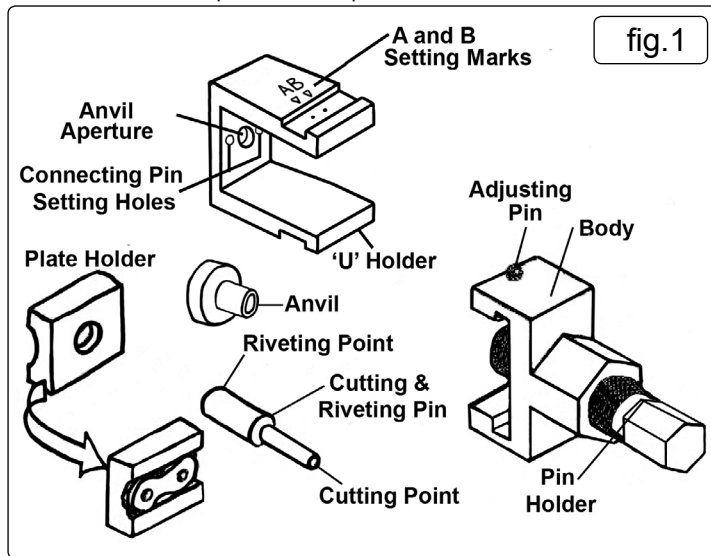

### 4.2. PRESS FITTING LINK PLATE

- 4.2.1. Connect the two ends of the chain with a new connecting link.

**Note:** Ensure that O rings are correctly positioned between the plates, and that the plates are adequately lubricated - see manufacturer's instructions (fig.5).

- 4.2.2. Position the U holder over the link so that the end of the plate's pins fit into the 2 recesses (fig.3.2).
- 4.2.3. Fit a suitably sized pin into the pin holder and position the plate holder over the end of the pin (fig.3.3).
- 4.2.4. Slide the pin holder body onto the U holder and tighten the securing screw in position A (fig.3.4).
- 4.2.5. Screw in the pin holder so that the plate holder is in contact with the new link (fig.3.5).
- 4.2.6. Use a 27mm spanner to hold the pin holder body and a 19mm spanner to turn the pin holder. Turn the pin holder clockwise and proceed to start push fitting the link plate onto the pins (fig.3.6). Back off the pin holder and remove the plate holder, then follow the instructions for riveting in 4.3.3.

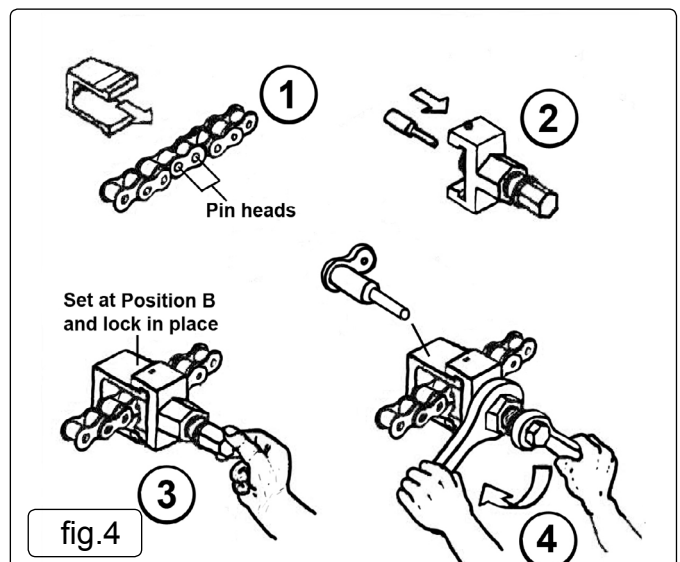
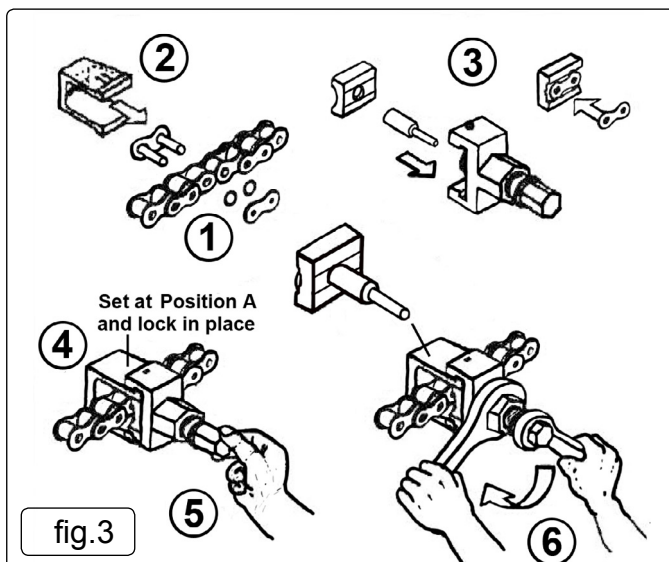

### 4.3. RIVETING PINS

- 4.3.1. Loosen securing screw and reposition the pin holder body on the U holder in position B and re-tighten the securing screw (fig.4.3).
- 4.3.2. Screw in the pin holder, ensuring that the riveting pin is positioned centrally onto one of the pin heads (fig.4.1).
- 4.3.3. Use a 27mm spanner to hold the pin holder body and a 19mm spanner to turn the pin holder. Turn the pin holder clockwise and start to push the riveting pin onto the pin. Keep checking to ensure that the riveting pin is centrally located on the pin and that it is cleanly riveting it.
- 4.3.4. The rivet should be clean, centred and deep enough, see fig.6.
- 4.3.5. When the first pin has been riveted, undo the pin holder, re-position the chain so that the other pin is lined up with the riveting pin and repeat the above procedure in 4.3.3.

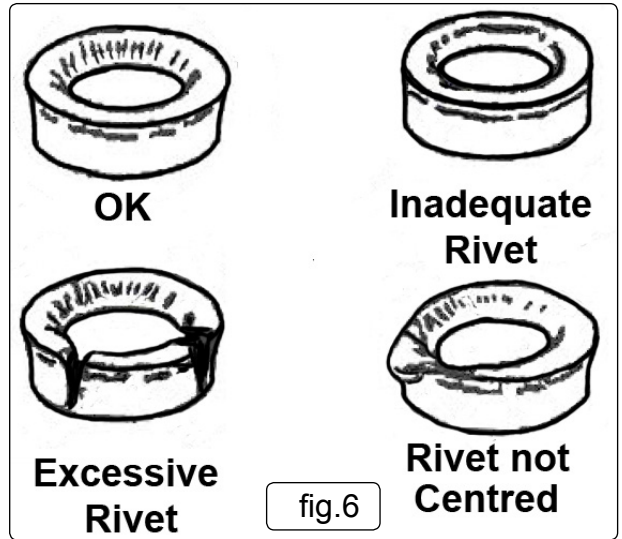
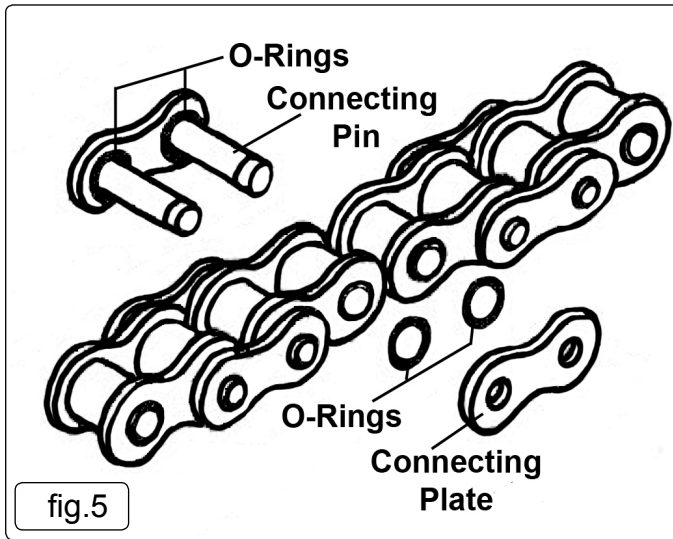

## 5. MAINTENANCE

- 5.1. Clean the tools and lubricate threads before each use.



### ENVIRONMENT PROTECTION

Recycle unwanted materials instead of disposing of them as waste. All tools, accessories and packaging should be sorted, taken to a recycling centre and disposed of in a manner which is compatible with the environment. When the product becomes completely unserviceable and requires disposal, drain any fluids (if applicable) into approved containers and dispose of the product and fluids according to local regulations.

**Note:** It is our policy to continually improve products and as such we reserve the right to alter data, specifications and component parts without prior notice.

**Important:** No Liability is accepted for incorrect use of this product.

**Warranty:** Guarantee is 12 months from purchase date, proof of which is required for any claim.

Sealey Group, Kempson Way, Suffolk Business Park, Bury St Edmunds, Suffolk. IP32 7AR

01284 757500

01284 703534

sales@sealey.co.uk

www.sealey.co.uk