

Thank you for purchasing a Sealey product. Manufactured to a high standard this product will, if used according to these instructions and properly maintained, give you years of trouble free performance.



IMPORTANT: PLEASE READ THESE INSTRUCTIONS CAREFULLY. NOTE THE SAFE OPERATIONAL REQUIREMENTS, WARNINGS & CAUTIONS. USE THE PRODUCT CORRECTLY AND WITH CARE FOR THE PURPOSE FOR WHICH IT IS INTENDED. FAILURE TO DO SO MAY CAUSE DAMAGE AND/OR PERSONAL INJURY AND WILL INVALIDATE THE WARRANTY. PLEASE KEEP INSTRUCTIONS SAFE FOR FUTURE USE.

1. SAFETY INSTRUCTIONS

1.1. GENERAL SAFETY

- ❑ **WARNING!** Ensure Health & Safety, local authority, and general workshop practice regulations are adhered to when using this equipment.
- ✓ Familiarise yourself with the application and limitations of the oil drainer, as well as the potential hazards.
- ❑ **WARNING!** Disconnect the drainer from the air supply before changing accessories, servicing or performing any maintenance.
- ✓ Maintain the drainer in good condition (use an authorised service agent).
- ✓ Replace or repair damaged parts. *Use genuine parts only. Unauthorised parts may be dangerous and will invalidate the warranty.*
- ✓ Keep the work area clean, uncluttered and ensure there is adequate lighting.
- ✓ Keep the drainer clean for best and safest performance.
- ✓ Maintain correct balance and footing. Ensure the floor is not slippery and wear non-slip shoes.
- ❑ **WARNING!** While extracting high temperature oils, keep hands, face and body protected using suitable personal protective equipment (PPE).
- x **DO NOT** Extract caustic or flammable products.
- ✓ Keep children and unauthorised persons away from the working area.
- ❑ **WARNING!** ensure correct air pressure is maintained and not exceeded.
- ✓ Keep air hose away from heat, oil and sharp edges. Check air hose for wear before each use, and ensure that all connections are secure.
- x **DO NOT** use the drainer for any purpose other than that for which it is designed.
- x **DO NOT** operate the drainer if any parts are damaged or missing as this may cause failure and/or personal injury.
- x **DO NOT** stand on the drainer.
- x **DO NOT** adjust or tamper with the safety valve.
- x **DO NOT** move the drainer by the hose, or yank the hose from the air supply.
- x **DO NOT** place attachments close to your face (especially eyes, ears, etc.) and do not point hose at other persons or animals.
- x **DO NOT** allow untrained persons to operate the drainer.
- x **DO NOT** operate the drainer when you are tired or under the influence of alcohol, drugs or intoxicating medication.
- x **DO NOT** leave the drainer operating unattended.
- x **DO NOT** direct air from the air hose at yourself or others.
- ✓ When not in use disconnect from the air supply, vent reservoir and store in a safe, dry, childproof area.
- ✓ Dispose of waste oil in accordance with local authority regulations.
- ❑ **WARNING! DO NOT** pollute the environment by allowing uncontrolled discharge of waste oil.
- ▲ **DANGER! DO NOT** release drain pan clamp lever when there is pressure in the reservoir as pipe and drain pan will be propelled upward with force. This could result in damage and/or serious injury.

2. INTRODUCTION

2.1. Introduction

- 2.1.1. Steel fabricated 110ltr reservoir. Height adjustable steel drain pan, fitted with filter, and gravity feed reservoir with air discharge hose. Fitted with reservoir oil level indicator tube. Heavy-duty wheels and castors for easy mobility.

3. ASSEMBLY

3.1. Assembly

- 3.1.1. Connect the ball valve (fig.1.1) to the drain basin and tighten it with a suitable wrench.
- 3.1.2. Insert the assembled group into the reservoir tank and tighten the ring sleeve (fig.2.1). Adjust the height and lock in position using the hand wheel (fig.2.2).
- 3.1.3. Attach the hose with the ball valve adaptor (fig.3.1) to the base of the reservoir tank.

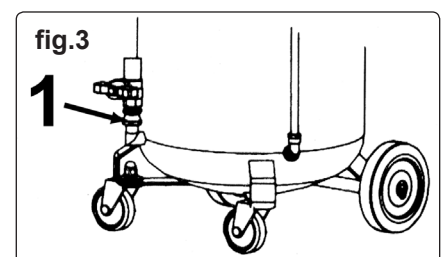
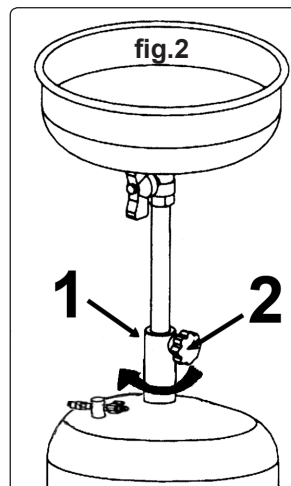
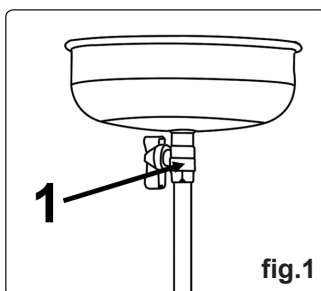

4. AIR SUPPLY

The recommended hook-up is shown in fig.4.

- 4.1. Ensure the air valve is in the "Off" position before connecting to the air supply.
- 4.2. You will require an air pressure of 0.45bar (7psi).
 WARNING! Ensure the air supply is clean and does not exceed pressures specified in these Instructions. Too high an air pressure and/or unclean air will shorten the drainer life due to excessive wear, and may be dangerous, causing damage and/or personal injury.
- 4.3. Drain the air tank daily. Water in the air line may damage the drainer.
- 4.4. Clean the air inlet filter screen weekly.
- 4.5. Line pressure should be increased to compensate for unusually long air hoses (over 8 metres). The minimum hose diameter should be 10mm I.D. and fittings must have the same inside dimensions.
- 4.6. Keep hose away from heat, oil and sharp edges. Check hoses for wear, and make certain that all connections are secure.

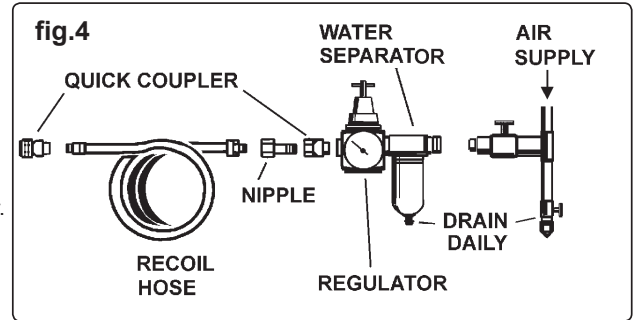

5. OPERATION

-
- WARNING! Ensure that you read, understand and apply the safety instructions in Section 1.**
- 5.1.
 - 5.1.1. To raise or lower the drain pan, slacken off the handwheel (fig.5.1) while supporting the weight of the drain pan, move drain pan to the correct height and then tighten the hand wheel.
- Note!** *Oil should be removed when hot (70-80°C). Keep hands, face and body protected using suitable personal protective equipment (PPE).*
- 5.1.2. Drain the oil into the drain pan ensuring that the drain pan valve is open (fig.5.2) and the ball valve tap at the base of the tank is closed (fig.3.1).
 - 5.1.3. When draining is complete, lower oil pan before moving drainer.
-
- WARNING! Ensure the oil level never rises above the maximum level on the indicator located on the side of the tank.**
- 5.2. **Emptying**
 - 5.2.1. Ensure that drain pan valve (fig.6.2) is closed and hand wheel (fig.6.1) is tight.
 - 5.2.2. Attach the end of the drain hose to a suitable waste oil container (fig.6).
 - 5.2.3. Open ball valve tap (fig.6.5).
 - 5.2.4. Connect air supply at a pressure of 0.45bar to coupling (fig.6.4) and open valve 3 (fig.6.3).
 - 5.2.5. After the fluids have been transferred from the tank close valve 5 (fig.6.5).
 - 5.2.6. Disconnect from air supply and vent any pressure remaining in the tank by opening drain pan valve (fig 6.2) and/or air valve (fig.6.3.).
- Note!** *This unit is equipped with a safety valve that has been factory set to cut in at a maximum of 0.45bar (7psi).*

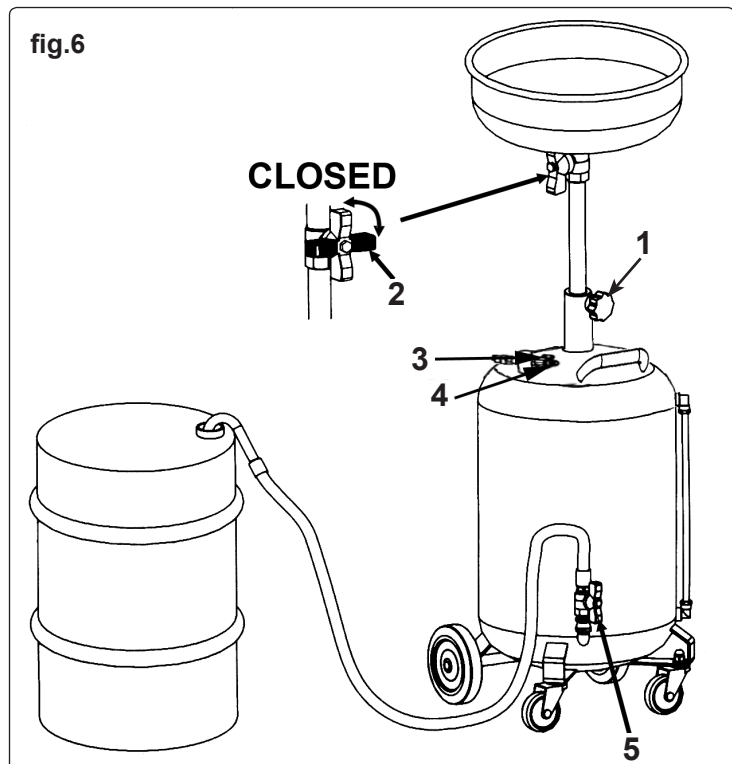
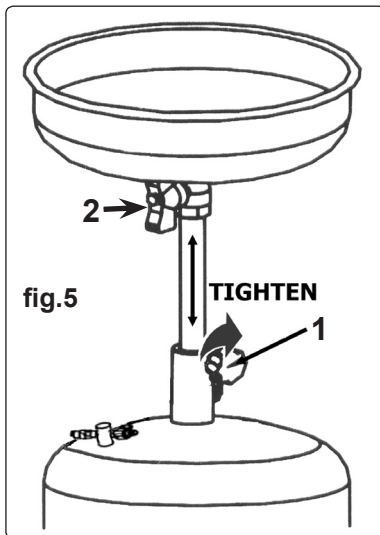

NOTE: It is our policy to continually improve products and as such we reserve the right to alter data, specifications and component parts without prior notice.

IMPORTANT: No liability is accepted for incorrect use of this product.

WARRANTY: Guarantee is 12 months from purchase date, proof of which will be required for any claim.

INFORMATION: For a copy of our latest catalogue and promotions call us on 01284 757525 and leave your full name and address, including postcode.



Sole UK Distributor, Sealey Group,
Kempson Way, Suffolk Business Park,
Bury St. Edmunds, Suffolk,
IP32 7AR

01284 757500

www.sealey.co.uk

01284 703534

sales@sealey.co.uk