

Thank you for purchasing a Sealey Product. Manufactured to a high standard this product will, if used according to these instructions and properly maintained, give you years of trouble free performance.



**IMPORTANT: PLEASE READ THESE INSTRUCTIONS CAREFULLY. NOTE THE SAFE OPERATIONAL REQUIREMENTS, WARNINGS AND CAUTIONS. USE THIS PRODUCT CORRECTLY AND WITH CARE FOR THE PURPOSE FOR WHICH IT IS INTENDED. FAILURE TO DO SO MAY CAUSE DAMAGE AND/OR PERSONAL INJURY AND WILL INVALIDATE THE WARRANTY. PLEASE KEEP INSTRUCTIONS SAFE FOR FUTURE USE.**

## 1. SAFETY

- WARNING!** Ensure that Health and Safety, local authority and general workshop practice regulations are adhered to when using this product.
- DO NOT** use this product if damaged.
- Maintain product in good and clean condition for best and safest performance.
- If the vehicle to be worked on is raised, ensure that it is adequately supported with axle stands or ramps and chocks.
- Wear approved eye protection. A full range of personal safety equipment is available from your Sealey dealer.
- Wear suitable clothing to avoid snagging. Do not wear loose jewellery and tie back long hair.
- Account for all tools and parts being used.
- If working off the vehicle, secure the work piece in a vice or clamp it to a work bench.
- DO NOT** operate puller if you are tired or under the influence of alcohol, drugs or intoxicating medication.
- \* **IMPORTANT:** Always refer to the vehicle manufacturer's service instructions, or a proprietary manual, to establish the current procedure and data. These instructions are provided as a guide only.

## 2. INTRODUCTION

### 2.1. Introduction

Fully chromed carbon steel medium stroke slide hammer. 370mm Overall length with 1.4kg hammer. Bearing extractor collets with internal capacity from 11 to 32mm. Supplied in carry-case.

## 3. CONTENTS

- 26mm - 32mm Attachment (Part No: AK714.V2-01)
- 20mm - 25mm Attachment (Part No: AK714.V2-02)
- Slide hammer (Part No: AK714.V2-03)
- 15mm - 20mm Attachment (Part No: AK714.V2-04)
- 11mm - 15mm Attachment (Part No: AK714.V2-05)

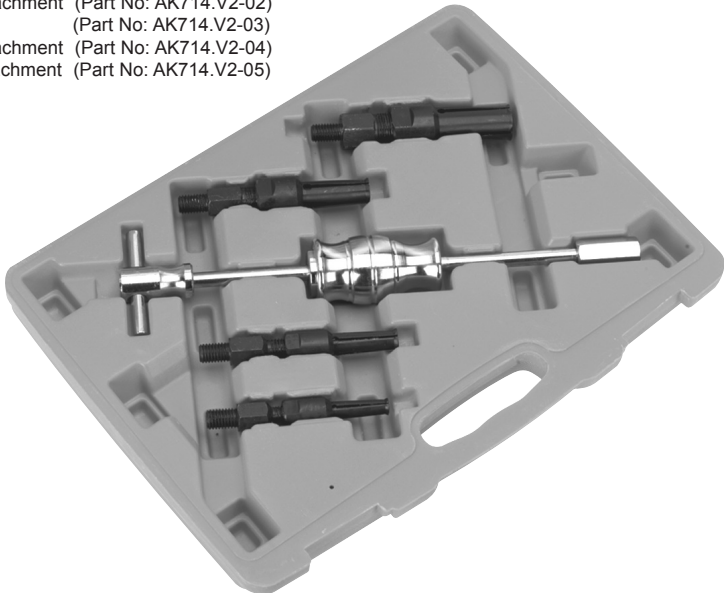

## 4. INSTRUCTIONS

- 4.1. Prior to use of the required attachment, disassemble and grease as shown in fig.1. Reassemble the attachment.

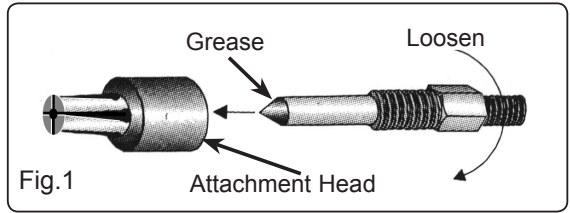

- 4.2. Screw the attachment into the shaft, as shown in fig.2. Tighten the attachment using a wrench. **Note:** Do not over tighten.

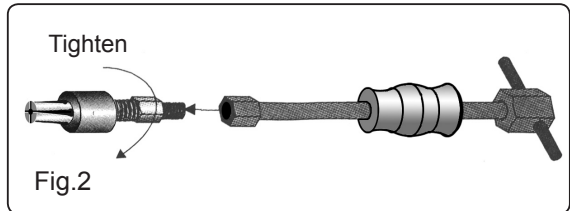

- 4.3. Ensure the attachment jaws are completely closed and insert the attachment into the inner diameter of the bearing, fig.3.

- 4.4. Turn the handle clockwise to open the attachment jaws to grip the bearing. See fig.4.

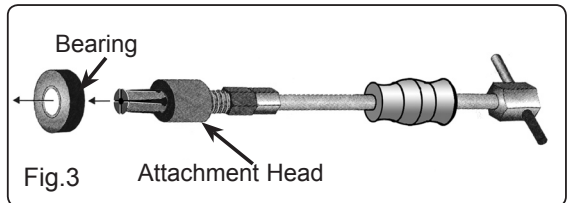

- 4.5. Hold the bearing puller as shown in fig.5, slide the hammer to the bearing end of the shaft and then forcefully pull the hammer to the other end of the shaft.

- 4.6. Ensure the bearing is being pulled out evenly, if not, remove the puller attachment and, using a soft faced mallet, tap the bearing until it is seated evenly.

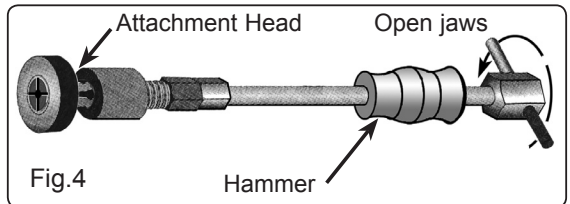

- 4.7. Repeat paragraphs 4.5 and 4.6 until the bearing has been removed.

- 4.8. Turn the handle anticlockwise to close the jaws in order to release the bearing from the attachment head. See fig.5.

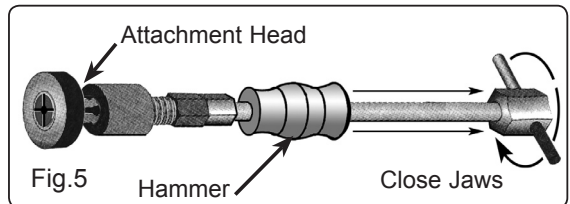

**NOTE:** It is our policy to continually improve products and as such we reserve the right to alter data, specifications and component parts without prior notice.

**IMPORTANT:** No liability is accepted for incorrect use of this product.

**WARRANTY:** Guarantee is 12 months from purchase date, proof of which will be required for any claim.

**INFORMATION:** For a copy of our latest catalogue and promotions call us on 01284 757525 and leave your full name and address, including postcode.



Sole UK Distributor, Sealey Group,  
Kempton Way, Suffolk Business Park,  
Bury St. Edmunds, Suffolk,  
IP32 7AR

01284 757500

www.sealey.co.uk

01284 703534

sales@sealey.co.uk