

Thank you for purchasing a Sealey product. Manufactured to a high standard this product will, if used according to these instructions and properly maintained, give you years of trouble free performance.

⚠ IMPORTANT: PLEASE READ THESE INSTRUCTIONS CAREFULLY. NOTE THE SAFE OPERATIONAL REQUIREMENTS, WARNINGS & CAUTIONS. USE THE PRODUCT CORRECTLY AND WITH CARE FOR THE PURPOSE FOR WHICH IT IS INTENDED. FAILURE TO DO SO MAY CAUSE DAMAGE AND/OR PERSONAL INJURY AND WILL INVALIDATE THE WARRANTY. PLEASE KEEP INSTRUCTIONS SAFE FOR FUTURE USE.

1. SAFETY INSTRUCTIONS

GENERAL SAFETY.

- ❑ **WARNING!** Ensure Health & Safety, local authority, and general workshop practice regulations are adhered to when using this equipment.
- ❑ **WARNING!** Wear approved safety hand and eye protection (standard spectacles are not adequate).
- ❑ **WARNING! TRAPPING DANGER** – Keep hands and fingers away from the spring and compressing jaws when in use.
- ✓ Keep the work area clean, uncluttered and ensure there is adequate lighting.
- ✓ Maintain correct balance and footing. Ensure the floor is not slippery and wear non-slip shoes.
- ✓ Remove ill-fitting clothes. Remove ties, watches, rings, other loose jewellery. Contain and/or tie back long hair.
- ✓ Wear appropriate protective clothing.
- ✓ Familiarise yourself with the applications, limitations and potential hazards of the spring compressor.
- ✗ DO NOT use the spring compressor for a task it is not designed to perform.
- ✗ DO NOT allow untrained persons to use the spring compressor.

PRE OPERATIONAL SAFETY.

- ✓ Strut and Spring Compression station should be securely bolted to the workshop floor before use.
- ✓ Apply grease to the front and rear faces of the main upright to assist the smooth action of the compressor.
- ✗ DO NOT operate spring compressor if parts are damaged or missing as this may cause failure and/or personal injury.
- ✓ Before commencing compression, make visual inspection of machine to ensure pins are securely positioned and that there is no sign of wear or fatigue – if found, do not use the unit and refer to your local Sealey dealer for advice and replacement parts.
- ✓ Ensure jaw locating pins are properly positioned and safety clips are attached correctly.
- ✓ Before commencing compression of spring, ensure coils of the spring are seated securely in the jaws of the compressor and cannot slide out during compression.
- ✓ Always fit a safety chain around strut and spring (ensure chain is not trapped in the coils of the spring being compressed).

OPERATIONAL SAFETY.

- ✓ When applying compression to the spring, always stand to one side of the unit.
- ▲ **DANGER!** Do not put hands or fingers near the spring as it is being compressed.
- ▲ **DANGER!** Stop compressing the spring before the coils touch.
- ✓ Before attempting to remove top cap nut, always use a tool or short stick to test if the compression has been relieved. Do not use your hands / fingers.
- ✓ Sealey recommends the use of purpose made strut tools to remove the top-nut from the shock absorber piston.
- ✓ Once compressed, and the strut removed, we recommend releasing the tension on the spring. Do not leave the spring under compression in the machine unattended and do not leave in compression for prolonged periods i.e. overnight.
- ✓ Before releasing the compression ensure that the top strut-nut is securely fastened to the maker's tolerance.
- ✓ Release the compression slowly keeping your hands and fingers away from the spring assembly.
- ✓ Be sure that the tension on the spring is fully controlled by

the strut assembly before removing it from the jaws of the compressor.

POST OPERATIONAL SAFETY.

- ✓ When not in use, clean and store the spring compressor in a safe, dry, childproof location.
- ✓ Maintain the spring compressor in good condition. Replace or repair damaged parts. Use genuine parts only. Unauthorised parts may be dangerous and will invalidate the warranty.

2. INTRODUCTION & KIT CONTENTS

2.1 The RE230UK kit enables owners of the RE230 spring compressor to fit an improved type of clamping jaw to their existing units (See figs.1 & 2 below). This system allows removal of the shock absorber from the spring without the need to remove the assembly from the compressor. The plastic coated yokes reduce the risk of spring slippage or damage and are suitable for springs from Ø102mm to Ø160mm. Before using the converted unit you must read the safety guide on this page and the revised instructions for use over-leaf. When converted the unit should conform to the technical specification shown in section 3.

- 2.2 CONTENTS: UPPER STRUT SUPPORT
 LOWER STRUT SUPPORT
 ONE PAIR SMALL JAWS
 ONE PAIR LARGE JAWS
 SAFETY CHAINS AND ATTACHMENTS

**RE230
 (ORIGINAL)**



Fig.1

**RE230
 CONVERTED**



Fig.2

3. TECHNICAL SPECIFICATION

Maximum Load	1000kg
Lower Yoke Travel340mm
Spring Diameters102-160mm
Upper Yoke positions7

4. CONVERSION PROCEDURE

- 4.1 First remove both strut support brackets from the existing unit.
UPPER BRACKET(Fig.3): Remove the 'R' clips 'E' & 'G' from the two long pins which hold the bracket in place. Support the bracket and its adjustable jaws and remove the two pins 'D' & 'F'. Slide the bracket up and off the main pillar. Retain the two clips and the two long pins for use with the new bracket.
LOWER BRACKET(Fig.4): The lower strut support bracket is attached to the top of the ram with a grub screw which passes through a saddle mounted on a pin in the back of the bracket. Remove the grub screw 'Z' and slide the bracket up and off the main pillar.
- 4.2 The new lower strut support already has a pin mounted saddle fitted within it. Slide the new lower strut support over the main pillar (see 'X' in Fig.5) until the top of the ram passes into the saddle. Once you are sure that the top of the ram has passed fully into the saddle tighten the grub screw mounted in the side of the saddle (see 'A' in Fig.5).
- 4.3 Slide the new upper strut support 'Y' over the main pillar to the required height and align the two holes in the support with two holes in the pillar. Slide the two long pins (see D & F in Fig.6) through the assembly and retain them in position using the 'R' clips (see E & G in Fig.6).
- 4.4 Two pairs of support jaws are supplied, one large pair and one small pair. To fit either pair of jaws see Fig.7. Hold the chosen jaw in place within each support bracket and slide the connecting pin 'K' back into place and retain it with the 'R' clip. Replace the socket cap bolt 'J'. The jaws are designed to be used as matched pairs and should not be mixed.

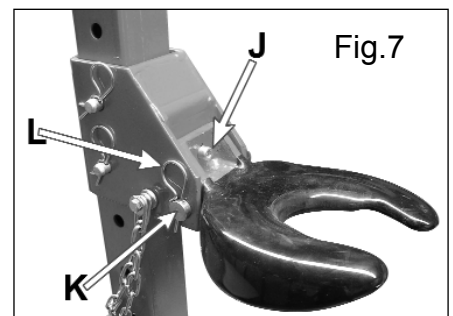
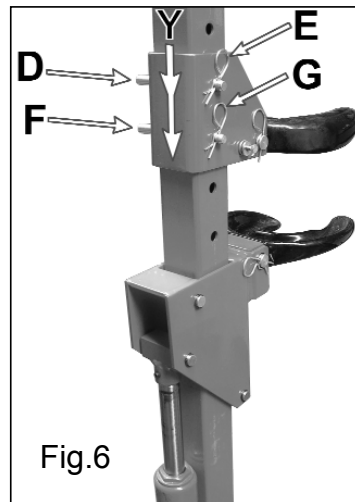
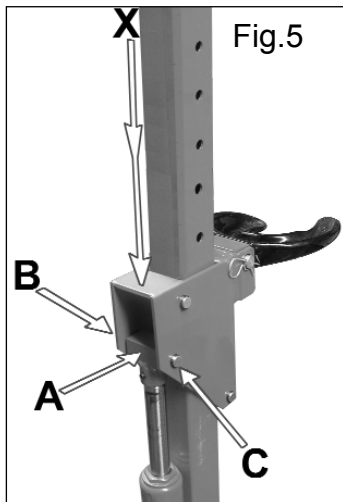
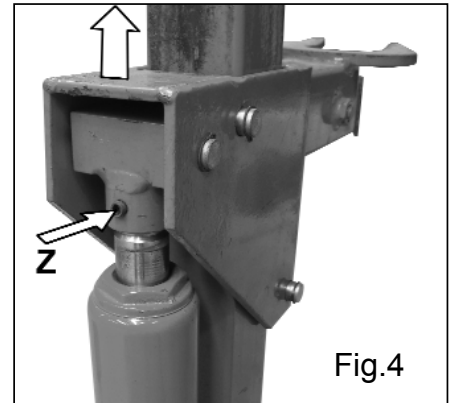
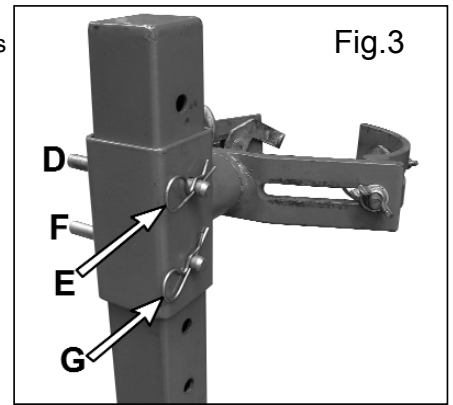

- 4.5 The converted unit must now be fixed securely to the ground in order to ensure the safety of the user. Holes are to be found in the brackets, which allow the unit to be secured by way of masonry bolts or sinking pins into concrete.
- WARNING!** Whichever method is used, ensure the unit is adequately fixed and cannot topple.

5. INSTRUCTIONS FOR USE

- 5.1 Measure the outer diameter of the spring to be compressed and select the correct set of jaws. Fit the jaws as described in para.4.4.
- 5.2 Operate the release valve pedal (fig.8-B) and press down on the lower strut support until the piston is full retracted.
- 5.3 The upper jaw should bear down on the first full coil down from the top of the strut. The lower jaw should be pushing up on the first full coil up from the bottom of the strut. Measure the distance between these coils and adjust the position of the upper strut support so that the distance between the jaws is slightly larger than required. Ensure that the pins fixing the upper support are fully inserted and retained with the spring clips provided. Use the foot pedal (fig.8-A) to raise the lower jaw/strut support to finely adjust the distance between the jaws.
- 5.4 Before commencing compression, make a visual inspection of machine to ensure pins are securely positioned and that there is no sign of wear or fatigue – if found, do not use the unit and refer to your local Sealey dealer for advice and replacement parts.
- 5.5 Insert the strut into the jaws and ensure that the lower coil used lies behind the retaining rim at the back of the jaw. Operate the foot pedal to raise the upper coil used into contact with the upper jaw ensuring once again that the coil is retained by the raised rim within the jaw.
- 5.6 Wrap a safety chain around the portion of the spring and strut protruding from the upper jaw ensuring that the chain lies above the jaw. Wrap another chain around the spring and strut protruding from the lower jaw ensuring that the chain lies below the jaw. Fasten each chain behind the main pillar using the sprung catches attached. Make sure each chain is as tight as possible. Do not position the chain between the coils held between the jaws.
- 5.7 When applying compression to the spring, always stand to one side of the unit and keep hands and fingers away from the assembly during compression.

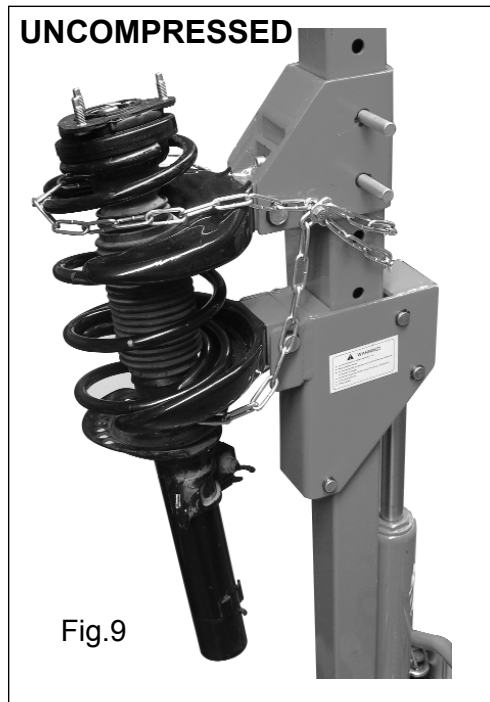
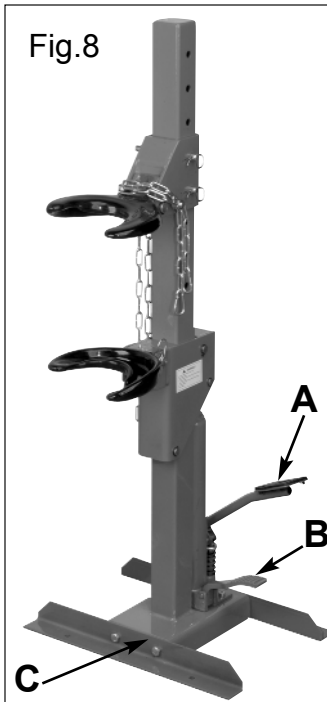

- 5.8 Gradually compress the spring by pumping the foot pedal ensuring that the spring and strut remain securely held at all times. Ensure that the strut and the body of the compressor are correctly aligned at all times during spring compression. For conical springs, the centre line of the spring should remain parallel to the compressor body.
- ▲ **DANGER!** Stop compressing the spring before the coil windings touch. You need only compress the spring until the strut top plate is free from the spring.
- 5.9 Before attempting to remove top cap nut, always use a tool or short stick to test if the spring compression has been relieved from the top plate. Do not use your hands / fingers. Sealey recommends the use of purpose made strut tools to remove the top-nut from the shock absorber piston (SX300, SX301, SX302). Ensure that the shock absorber is supported as the top nut is undone to prevent it falling down through the coils and causing injury.
- 5.10 Once compressed, and the strut removed, we recommend releasing the tension on the spring. Do not leave the spring under compression in the machine unattended and do not leave in compression for prolonged periods i.e. overnight.
- 5.11 Allow the spring to gradually decompress by carefully operating the valve release pedal keeping your hands and fingers away from the spring assembly.
- 5.12 Replace the spring or shock absorber as necessary and reassemble the strut by first compressing the spring and then introducing the shock absorber up through the lower jaw and compressed spring coils. Re-attach the top plate and top nut.
- 5.13 Before releasing the compression ensure that the top strut-nut is securely fastened to the maker's tolerance.
- 5.14 Release the compression slowly keeping your hands and fingers away from the spring assembly.
- 5.15 Be sure that the tension on the spring is fully controlled by the strut assembly before removing it from the jaws of the compressor and that the top cap is secured in the top windings of the spring.

6. MAINTENANCE

- 6.1 Before each use, check the compressor to ensure it is not damaged or worn. If in any doubt DO NOT use the unit. Remove it from service immediately and contact your local Sealey dealer for advice/repairs.
- 6.2 Refilling the hydraulic system with oil is rarely necessary but the level should be checked in the event of a loss of performance. To check oil level, ensure the ram is fully lowered, remove filler plug and check that level is within 10mm of filler hole. Add hydraulic jack oil if necessary.
- NOTE:** Use a good quality jack oil, such as SEALEY HYDRAULIC JACK OIL.
- ☐ **WARNING: DO NOT use brake fluid, or any fluid other than hydraulic jack oil as this will cause serious damage to the jack and will invalidate the warranty!**

7. DECLARATION OF CONFORMITY

STRUT & SPRING COMPRESSING STATIONS
Model: RE230 & RE231
 98/37/EC Machinery Directive
 93/68/EEC CE Marking Directive

We, the sole importer into the UK, declare that the products listed here are in conformity with the following standards and directives.



Signed by
 Tim Thompson

18th January 2006

For Jack Sealey Ltd. Sole importer into the UK of Sealey Professional Tools.

The construction files for these products are held by the Manufacturer and may be inspected, by a national authority, upon request to Jack Sealey Ltd.



Sole UK Distributor
 Sealey Group,
 Bury St. Edmunds, Suffolk.

☎ 01284 757500
 📠 01284 703534

🌐 www.sealey.co.uk
 ✉ sales@sealey.co.uk