



INSTRUCTIONS FOR MOTORCYCLE WHEEL BALANCER

MODEL No: **VS1819.V3**

Thank you for purchasing a Sealey product. Manufactured to a high standard this product will, if used according to these instructions and properly maintained, give you years of trouble free performance.



IMPORTANT: PLEASE READ THESE INSTRUCTIONS CAREFULLY. NOTE THE SAFE OPERATIONAL REQUIREMENTS, WARNINGS AND CAUTIONS. USE THE PRODUCT CORRECTLY AND WITH CARE FOR THE PURPOSE FOR WHICH IT IS INTENDED. FAILURE TO DO SO MAY CAUSE DAMAGE AND/OR PERSONAL INJURY AND WILL INVALIDATE THE WARRANTY. PLEASE KEEP INSTRUCTIONS SAFE FOR FUTURE USE.

1. SAFETY INSTRUCTIONS

GENERAL SAFETY

- ❑ **WARNING!** Ensure Health & Safety, local authority, and general workshop practice regulations are adhered to when using this equipment. Under Health and Safety Law, Employers and Self Employed Personnel have a legal duty to ensure Safe Working Conditions for all employees and personnel that may come into contact with this equipment. In particular they must carry out a specific risk and hazard assessment in the workplace to eliminate or reduce any risk found and must record, update and retain records of the results of this inspection.
- ✓ Familiarise yourself with the applications, limitations and any possible or potential hazards of the Wheel Balancer.
- ✓ Maintain the Wheel Balancer in good condition.
- ✓ Replace or repair damaged parts. Use genuine parts only. Unauthorised parts may be dangerous and will invalidate the warranty.
- ❑ **WARNING!** Check regularly for damaged parts. Any part that is damaged must be repaired or replaced before the equipment is next used.
- ✓ Locate the Wheel Balancer in a suitable work area, keep area clean and tidy and free from unrelated materials.
- ✓ Ensure that there is adequate lighting.
- ✓ Keep the Wheel Balancer clean for best and safest performance.
- ✓ Remove ill fitting clothing. Remove ties, watches, rings and other loose jewellery and contain and/or tie back long hair.
- ✓ Keep children and unauthorised persons away from the work area.
- x **DO NOT** use the Wheel Balancer for any purpose other than that for which it is designed.
- x **DO NOT** operate the Wheel Balancer if any parts are damaged or missing as this may cause failure and/or personal injury.

2. INTRODUCTION

Professional Motorcycle Wheel Balancer. Suitable for most motorcycle wheels. Includes two cones and spindle for precise, easy alignment and balancing. Uses gravity to find the heavy point of a wheel and tyre.

SPECIFICATION: Maximum Cone Size:.....Ø35mm
Centre Spindle to Base:.....400mm

3. ASSEMBLY / USE

3.1. Assembling the Wheel Balancer.

- 3.1.1. Place the uprights onto the base (with the bearings facing inwards). Secure to the base as shown in fig.1 below using two 13mm bolts, two washers and two 13mm nuts. You will require two 13mm spanners to hold the nuts steady and to tighten the bolts.
- 3.1.2. Place the bubble indicator over the hole in the base and align the three holes in its flange with the three holes in the base. Secure with the 3 small screws and nuts supplied. See fig.2.
- 3.1.3. Thread a 13mm nut onto each foot and screw it down to the bottom of the thread but leave it loose.
- 3.1.4. Screw the 4 feet into the base of the balancer, as shown in fig.1. Adjust the feet until the bubble indicator shows that the base is level.
- 3.1.5. Fix the positions of all four feet by tightening up the 13mm nut to the underside of the metalwork.

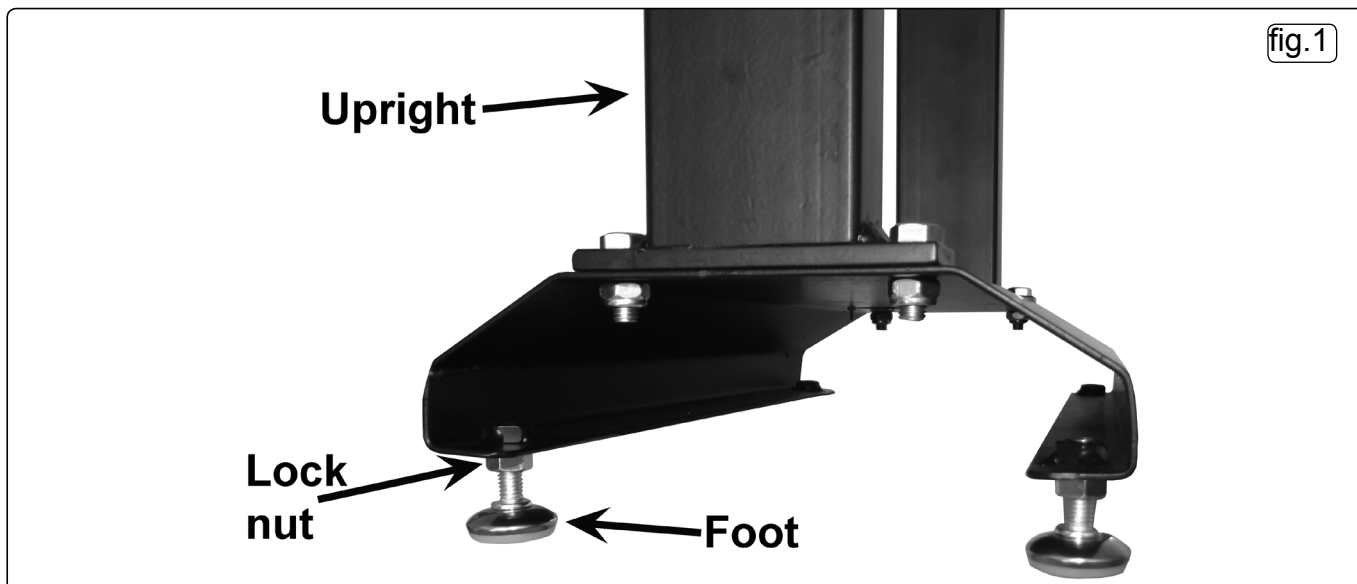

3.2. Using the Wheel Balancer

- 3.2.1. Use the balancer on a stable, level surface. If necessary adjust the feet until the bubble level is central. Screw the leg nuts tight to the base to secure the legs.**
- 3.2.2. Slide the balancer spindle through the motorcycle wheel hollow axle and slide a cone onto either end of the spindle so that the tapered ends enter the wheel bearings. When the wheel is central on the spindle, secure the cones by tightening the grub screw in each using a 3mm hex key. Check that the wheel is central on the spindle and firmly secured by the cones for best results. See fig.3
- 3.2.3. With the wheel securely on the wheel balancer, gently rotate the wheel. When the wheel settles, the spot at the bottom of the wheel is the heavy spot.
- 3.2.4. Now with the heavy spot at the bottom mark the top of the wheel directly opposite the heavy spot using chalk or adhesive tape. This is the light spot see fig.4A.
- 3.2.5. Gently spin the wheel again to ensure that the heavy spot will again settle at the bottom. (fig.4)
- 3.2.6. Attach some wheel weights to the rim of the wheel at the light spot (fig.4A) and spin the wheel gently.
- 3.2.7. If the light spot falls to the bottom, too much weight has been added to the wheel. If the heavy spot falls to the bottom, not enough weight has been added to the wheel. Add / Remove weight as required (fig.5)
- 3.2.8. Turn the light spot 90 degrees so it sits horizontally with the heavy spot and observe its movements, if again it falls to the bottom, too much weight has been added, if the heavy spot falls, too little weight has been added. (fig.5)
- 3.2.9. Repeat until the light spot and heavy spot are on a horizontal line through the centre of the wheel. Once this has been achieved the wheel should rest still at any position through the wheels circumference.

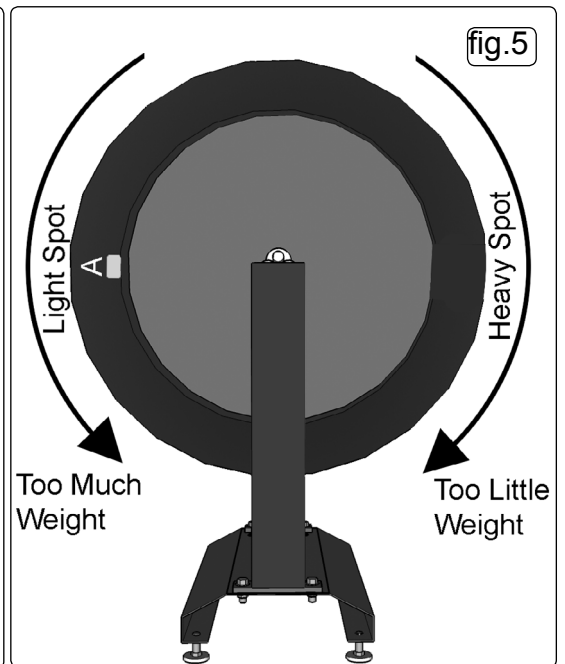
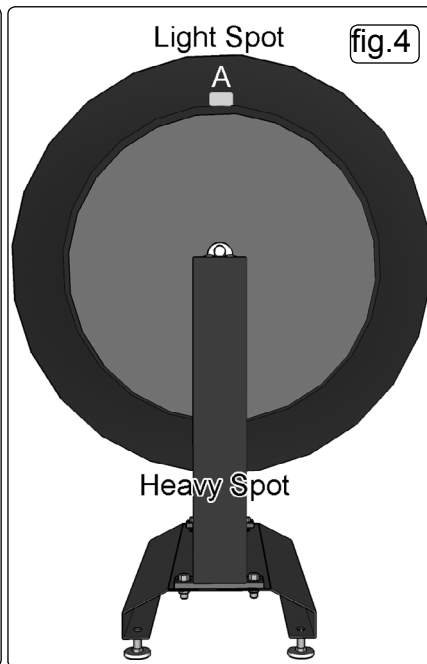
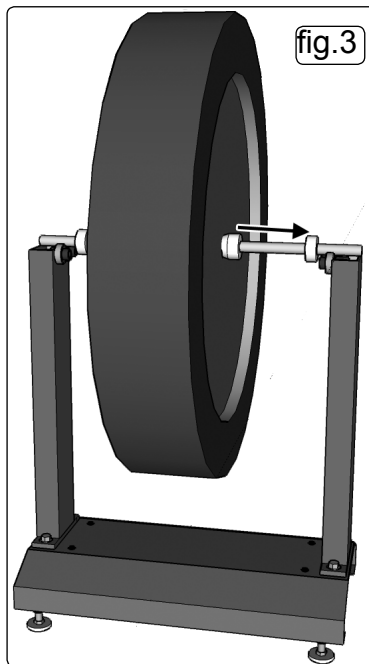
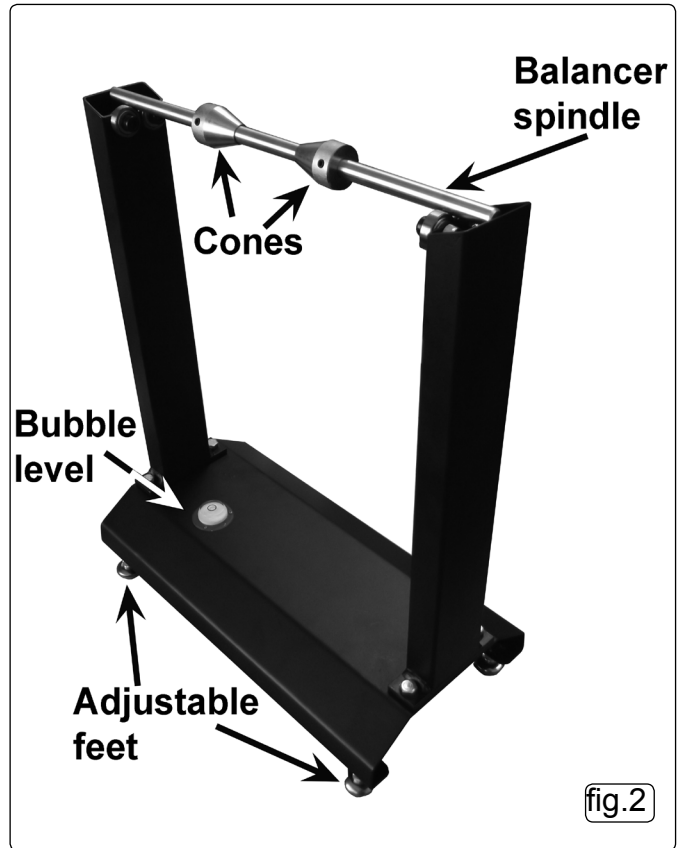

Environmental Protection.
 Recycle unwanted materials instead of disposing of them as waste. All tools, accessories and packaging should be sorted, taken to a recycle centre and disposed of in a manner which is compatible with the environment.

Parts support is available for this product. To obtain a parts listing and/or diagram, please log on to www.sealey.co.uk, email sales@sealey.co.uk or telephone 01284 757500.

NOTE: It is our policy to continually improve products and as such we reserve the right to alter data, specifications and component parts without prior notice.

IMPORTANT: No liability is accepted for incorrect use of this product.

WARRANTY: Guarantee is 12 months from purchase date, proof of which will be required for any claim.

INFORMATION: For a copy of our latest catalogue and promotions call us on 01284 757525 and leave your full name and address, including postcode.



Sole UK Distributor, Sealey Group,
 Kempson Way, Suffolk Business Park,
 Bury St. Edmunds, Suffolk,
 IP32 7AR

☎ 01284 757500

🌐 www.sealey.co.uk

📠 01284 703534

✉ sales@sealey.co.uk